

PROPORTIONAL VALVES

ABBREVIATIONS

AP	HIGH PRESSURE CONNECTION
AS	PHASE LAG (DEGREES)
BP	LOW PRESSURE CONNECTION
C	STROKE (MM)
CH	ACROSS FLATS
Ch	INTERNAL ACROSS FLATS
DA	AMPLITUDE DECAY (dB)
Dp	DIFFERENTIAL PRESSURE (BAR)
F	FORCE (N)
I%	INPUT CURRENT (A)
M	MANOMETER CONNECTION
NG	KNOB TURNS
OR	SEAL RING
P	LOAD PRESSURE (BAR)
PARBAK	PARBAK RING
PL	PARALLEL CONNECTION
Pr	REDUCED PRESSURE (BAR)
Q	FLOW (L/MIN)
Qp	PUMP FLOW (L/MIN)
SE	ELASTIC PIN
SF	BALL
SR	SERIES CONNECTION
X	PILOTING
Y	DRAINAGE

PROPORTIONAL VALVES



XD2A... / XD2C...	CAP. VIII • 2
XD3A... / XD3C...	CAP. VIII • 4
D15P PROPORTIONAL SOLENOIDS	CAP. VIII • 5
XDP3A... / XDP3C ...	CAP. VIII • 6
D15P PROPORTIONAL SOLENOIDS	CAP. VIII • 7
XDP5A... / XDP5C...	CAP. VIII • 8
D19P PROPORTIONAL SOLENOIDS	CAP. VIII • 9
XDC3... SERIE 2	CAP. VIII • 10
PROPORTIONAL SOLENOIDS XDC3	CAP. VIII • 11
XEPV3...	CAP. VIII • 12
AM3H...	CAP. VIII • 15
AM5H...	CAP. VIII • 16
XQ3...	CAP. VIII • 17
D15P PROPORTIONAL SOLENOIDS	CAP. VIII • 18
XQP3.	CAP. VIII • 19
D15P PROPORTIONAL SOLENOIDS	CAP. VIII • 20
XQP5.	CAP. VIII • 21
D15P PROPORTIONAL SOLENOIDS	CAP. VIII • 22
XP3...	CAP. VIII • 23
AM3XMP...	CAP. VIII • 25



XD2A... / XD2C... SOLENOID OPERATING PROPORTIONAL VALVES CETOP 2

XD2A../XD2C.. series valves are used for controlling fluid direction and flow rate as a function of the supply current to the proportional control solenoid.

Any valve Δp variation causes a change in the set flow rate; however the valve itself ensure a high level internal compensation maintaining constant a regulated flow.

The XD2 cetop valve could be used for accurate proportional controls with compact sizes, reducing weights.

These valves can be also combined with Mini Powerpacks type MR/MC/FP creating compact solutions. Could be also used on a Cetop 3 interface using a reduction plate type BS32001.

XD2...	
STANDARD CONNECTORS	CAP. I • 20
DC SOLENOID A09	CAP. I • 4
REMSRA...	CAP. IX • 4
REMDRA...	CAP. IX • 7
CEPS	CAP. IX • 2
AM3H...	CAP. VIII • 15
BS32001	CAP. VII • 3

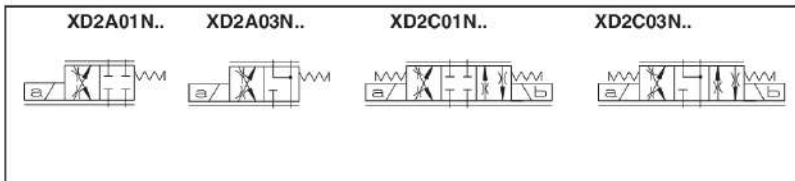

ORDERING CODE

XD	Proportional valve
2	CETOP 2/NG04
*	A = Single solenoid C = Double solenoid
**	Type of spool (null position)
	01 = 03 =
*	Flow path control (see symbols table) N = symmetrical
*	Flow rating l/min (Δp 5 bar) 1 = 1.5 l/min 6 = 6 l/min
*	Max. spool current F = 1.4 A G = 0.7 A
**	Variant: see Tab.1
1	Serial No.

TAB.1 - VARIANTS

No variant (without connectors)	S1(*)
Viton	SV(*)
AMP Junior connection	AJ(*)
Coil with flying leads (250 mm)	FL
Coil with flying leads (130 mm) with diode	LD
Deutsch connection with bidirectional diode	CX

(*) Coils with Hirschmann and AMP Junior connection supplied without connectors. The connectors can be ordered separately, Cap. I • 20.

INPUT SIGNAL CURVES - FLOW RATE

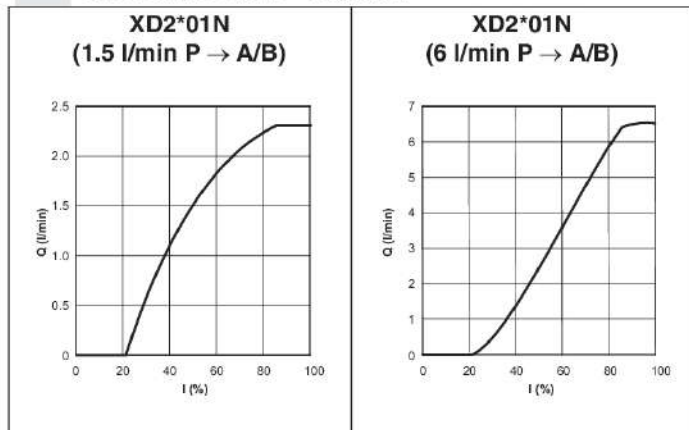

POWER LIMITS TRANSMITTED

P → A/B → T o P → B/A → T

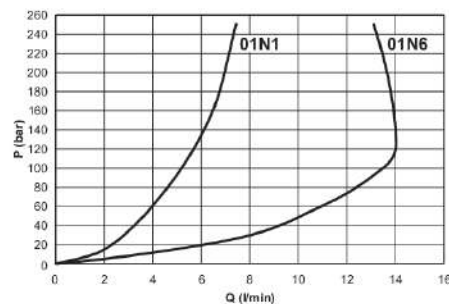

The fluid used was a mineral oil with a viscosity of 46 mm²/s at 40°C. The tests have been carried out at with a fluid of 40°C.

Performances shown in this catalogue are guaranteed only using a pressure compensator of 5 bar.

XD2A... / XD2C... SOLENOID OPERATING PROPORTIONAL VALVES CETOP 2

OPERATING SPECIFICATIONS

Max. operating pressure ports P/A/B	250 bar
Max. operating pressure ports T - for dynamic pressure see note (*)	250 bar
Regulated flow rate	1.5 / 6 l/min
Relative duty cycle	Continuous 100% ED
Type of protection	IP 65
Flow rate gain	See diagrams
Hysteresis with connection P/A/B/T $\Delta p = 5$ bar (P/A)	$\leq 13\%$ of max. flow rate
Fluid viscosity	$10 \div 500$ mm ² /s
Fluid temperature	$-20^{\circ}\text{C} \div 75^{\circ}\text{C}$
Max. contamination level	class 8 in accordance with NAS 1638 with filter $\beta_{10} \geq 75$
Weight XD.2.A... (single solenoid)	0.88 Kg
Weight XD.2.C... (double solenoid)	1.1 Kg
Max. current (voltage)	1.4A (a 12V) 0.7A (a 24V)
Solenoid coil resistance at 25°C (77°F)	5.3 Ohm 21.3 Ohm

(*) Pressure dynamic allowed for 500000 cycles

• Operating specifications are valid for fluid with 46 mm²/s viscosity at 40°C, using the specified electronic control units.

ELECTRONIC CONTROL UNIT

REMSRA** and REMDRA**

Card type control for single and double solenoid.
Recommended dither frequency 100 Hz.

CEPS

Electronic amplifier plug version
for single solenoid proportional valve (150Hz
PWM frequency setting)

OVERALL DIMENSIONS

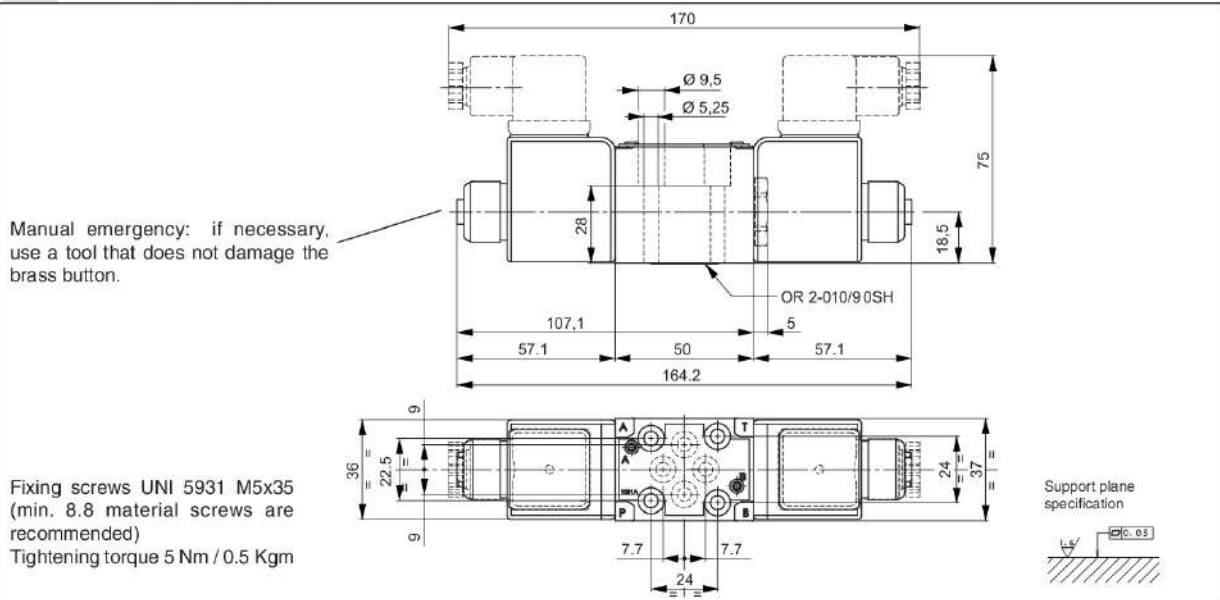

8



AMP JUNIOR (AJ)

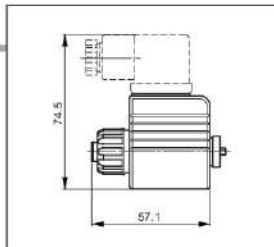
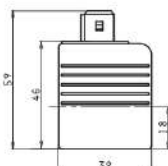

**FLYING LEADS (FL)
LEADS + DIODE (LD)**

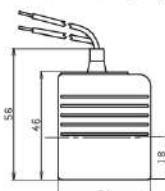

PROPORTIONAL SOLENOID

Type of protection (in relation to connector used)	IP 65
Number of cycle	18.000/h
Supply tolerance	$\pm 10\%$
Ambient temperature	$-30^{\circ}\text{C} \div 60^{\circ}\text{C}$
Duty cycle	100% ED
Insulation class wire	H
Weight	0,215 Kg

**DEUTSCH COIL + BIDIR. DIODE (CX)
DT04 - 2P**

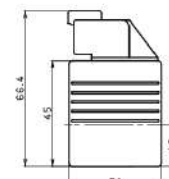



XD3A... / XD3C... SOLENOID OPERATING PROPORTIONAL VALVES CETOP 3

XD3A.../XD3C... series valves are used for controlling fluid direction and flow rate as a function of the supply current to the proportional control solenoid.

Any valve Δp variation causes a change in the set flow rate; however the valve itself ensure a high level internal compensation by limiting the controlled flow rate.

To ensure a constant flow rate and reduce leakage, we recommend to use AM3H2V or AM3H3V hydrostats.

Performances shown in this catalogue are guaranteed only using 2 or 3 way modular assembly hydrostats type AM3H. ...

The shown flow rates are typical for one line operation (e.g. from P to B), while higher flow rates are obtainable by using the valve with our flow rate doubling sub-base type BC307 (see diagram next page). This type of configuration extends considerably the flow rate limit.

XD3...	
STANDARD CONNECTORS	CAP. I • 20
"D15P" PROPORT. SOLENOIDS	CAP. VIII • 5
REMSRA...	CAP. IX • 4
REMRA...	CAP. IX • 7
AM3H...	CAP. VIII • 15
BC307...	CAP. VII • 12

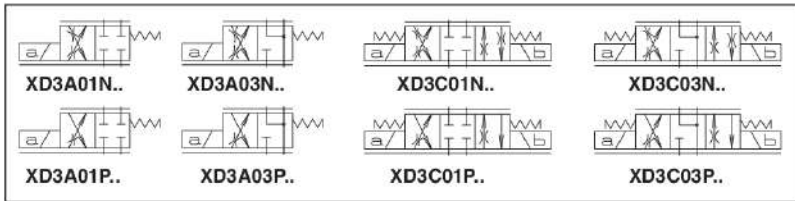

ORDERING CODE

XD	Proportional valve
3	CETOP 3/NG06
*	A = Single solenoid C = Double solenoid
**	Type of spool (null position)
	01 = 03 =
*	Flow path control (see symbols table) N = symmetrical P = meter in
*	Flow rating l/min (Δp 5 bar) 1 = 3 l/min 2 = 10 l/min 3 = 15 l/min 4 = 18 l/min
*	E = 2.35 A F = 1.76 A G = 0.88 A
**	Variant: see Tab.1
2	Serial No.

TAB.1 - VARIANTS (*)

No variant (without connectors)	S1
Viton	SV
Rotary emergency	P2
Rotary emergency 180°	R5

(*) All variants are considered without connectors. The connectors must be order separately. See Cap. I • 20.

INPUT SIGNAL CURVES - FLOW RATE

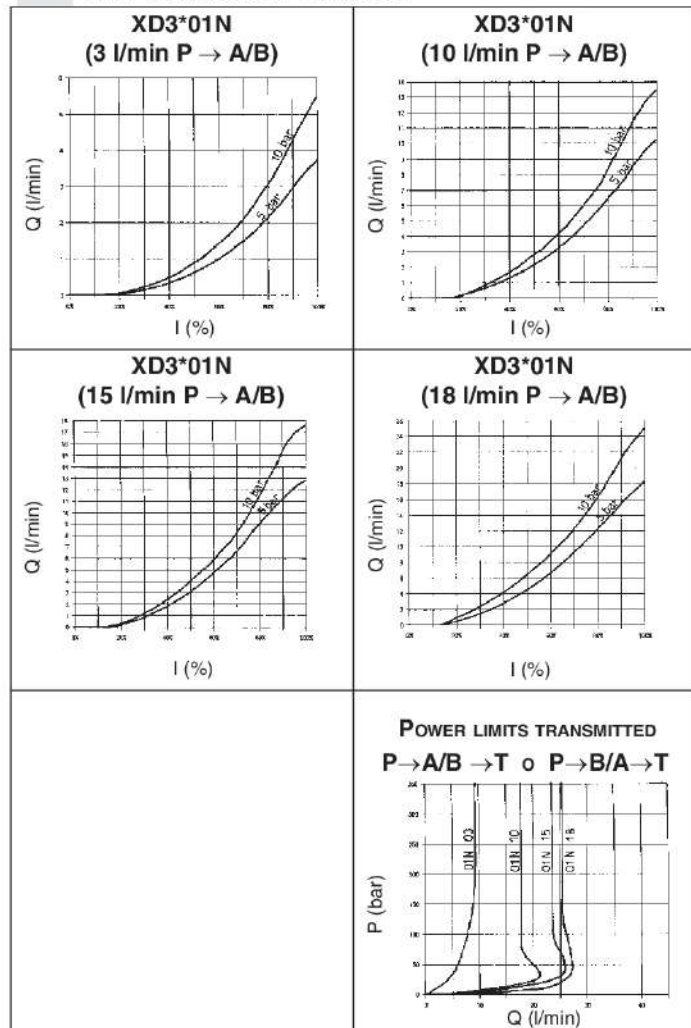

The fluid used is a mineral based oil with a viscosity of 46 mm²/s at 40°C. The tests have been carried out at with a fluid of a 40°C.

XD3A... / XD3C... SOLENOID OPERATING PROPORTIONAL VALVES CETOP 3

OPERATING SPECIFICATIONS

Max. operating pressure ports P/A/B	350 bar		
Max. operating pressure ports T - for dynamic pressure see note (*)	250 bar		
Regulated flow rate	3 / 10 / 15 / 18 l/min		
Relative duty cycle	Continuous 100% ED		
Type of protection	IP 65		
Flow rate gain	See diagrams		
Hysteresis with connection P/A/B/T $\Delta p = 5$ bar (P/A)	$\leq 7\%$ of max. flow rate		
Fluid viscosity	$10 \div 500$ mm ² /s		
Fluid temperature	$-20^{\circ}\text{C} \div 75^{\circ}\text{C}$		
Max. contamination level	class 8 in accordance with NAS 1638 with filter $\beta_{10} \geq 75$		
Weight XD.3.A... (single solenoid)	1,5 Kg		
Weight XD.3.C... (double solenoid)	1,7 Kg		
Type of voltage	9V	12V	24V
Max. current	2.35A	1.76 A	0.88 A
Solenoid coil resistance at 25°C (77°F)	2.25 Ohm	4.0 Ohm	16.0 Ohm

(*) Pressure dynamic allowed for 2 millions of cycles.

• Operating specifications are valid for fluid with 46 mm²/s viscosity at 40°C, using the specified electronic control units.

ELECTRONIC CONTROL UNIT

REMSRA** and REMDRA**

Card type control for single and double solenoid.
Recommended dither frequency 100 Hz.

AM3H2VP1 and AM3H3VP1

Hydrostats 2 or 3 way.

SCHEMA FOR DOUBLE FLOW RATE

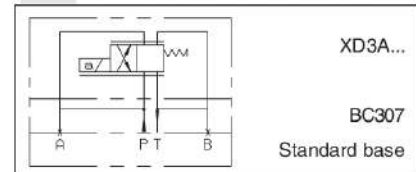

XD3A... OVERALL DIMENSIONS

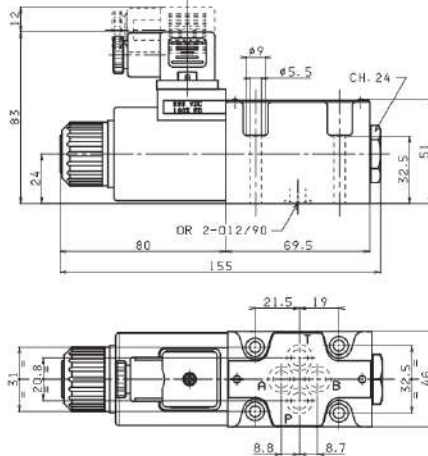

XD3C... OVERALL DIMENSIONS

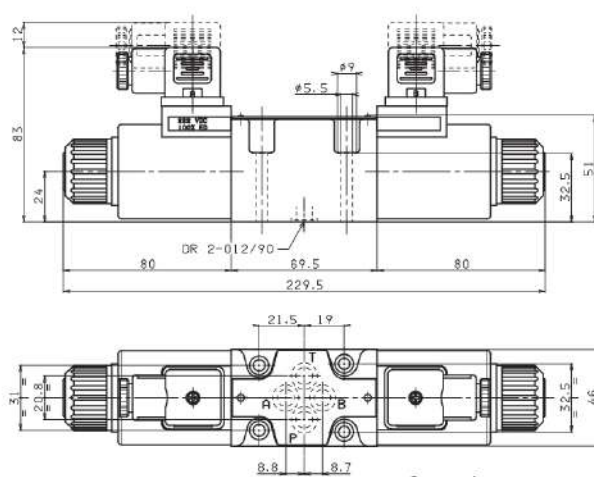

Fixing screws UNI 5931 M5x40 (min. 8.8 material screws are recommended)
Tightening torque 4 ÷ 5 Nm / 0.4 ÷ 0.5 Kg

Support plane specification

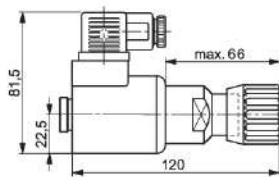
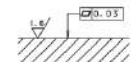

P2 Rotary emergency (1)

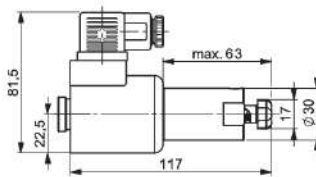

R5 Rotary emergency 180° (2)

- (1) P2 - Adjustable hand emergency.
- (2) R5 - Two positions hand emergency. The regulated flow with emergency actuated can be less than nominal value.

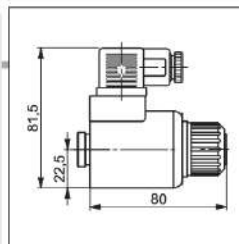

"D15P" PROPORTIONAL SOLENOIDS

Type of protection (in relation to connector used)	IP 66
Duty cycle	100% ED
Insulation class wire	H
Weight (coil)	0,354 Kg
Weight (solenoid)	0,608 Kg



XDP3A... / XDP3C ...

PROPORTIONAL DIRECTIONAL VALVES OPEN LOOP

The open loop valves of series XDP... control the direction and the volume of the flow according to the feeding current to the proportional solenoid. By using a valve body equipped with increased passage channels it is possible to reach the highest capacity of its dimensions at a parity of pressure drops, (40 l/min with Δp of 10 bar).

Each Δp variation on the valve leads to the variation of the capacity which has been set, anyway the valve guarantees an high inner compensation grade and limits the adjustment capacity.

Performances shown in this catalogue are guaranteed only using 2 or 3 way modular assembly hydrostats type AM3H. ... By using the valve with the base for capacity doubling type BC307 (see next page) a greater capacity can be obtained.

XDP3...	
STANDARD CONNECTORS	CAP. I • 20
D15P PROPORTIONAL SOLENOIDS	CAP. VIII • 7
REMSRA...	CAP. IX • 4
REMDRA...	CAP. IX • 7
AM3H...	CAP. VIII • 15
AM5H...	CAP. VIII • 16
BC307...	CAP. VII • 12

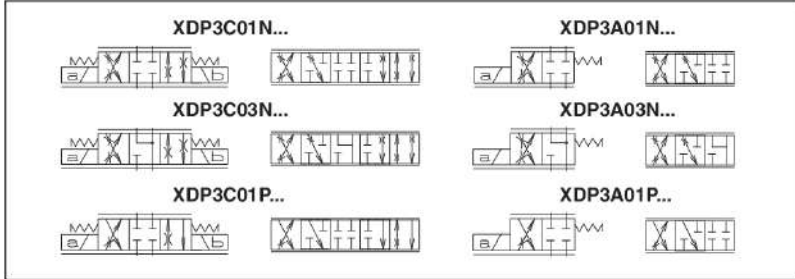

ORDERING CODE

XDP	Open loop proportional directional valve
3	CETOP 3/NG06
*	A = Single solenoid C = Double solenoid
**	Type of spool (null position)
	01 = 03 =
*	Flow path control (see hydraulic symbols table) N = simmetrico P = in mandata (solo con cursori 01)
*	Flow rating l/min (Δp 10 bar) A = 4 l/min 1 = 8 l/min 2 = 15 l/min 3 = 25 l/min 6 = 40 l/min In order to reduced the unloading pressure for rated flow version at 40 l/min we advise to use the 3 way type AM5H3V... hydrostat
*	Max. current to solenoid E = 2.35 A F = 1.76 A G = 0.88 A
**	Varianti: see Table 1
2	Serial No.

TABLE 1 - VARIANTS (*)

No variant (without connectors)	S1
Viton	SV
Rotary emergency	P2
Rotary emergency 180° 180°	R5

(*) All variants are considered without connectors. The connectors must be order separately. See Cap. I • 20.

INPUT SIGNAL CURVES - FLOW RATE

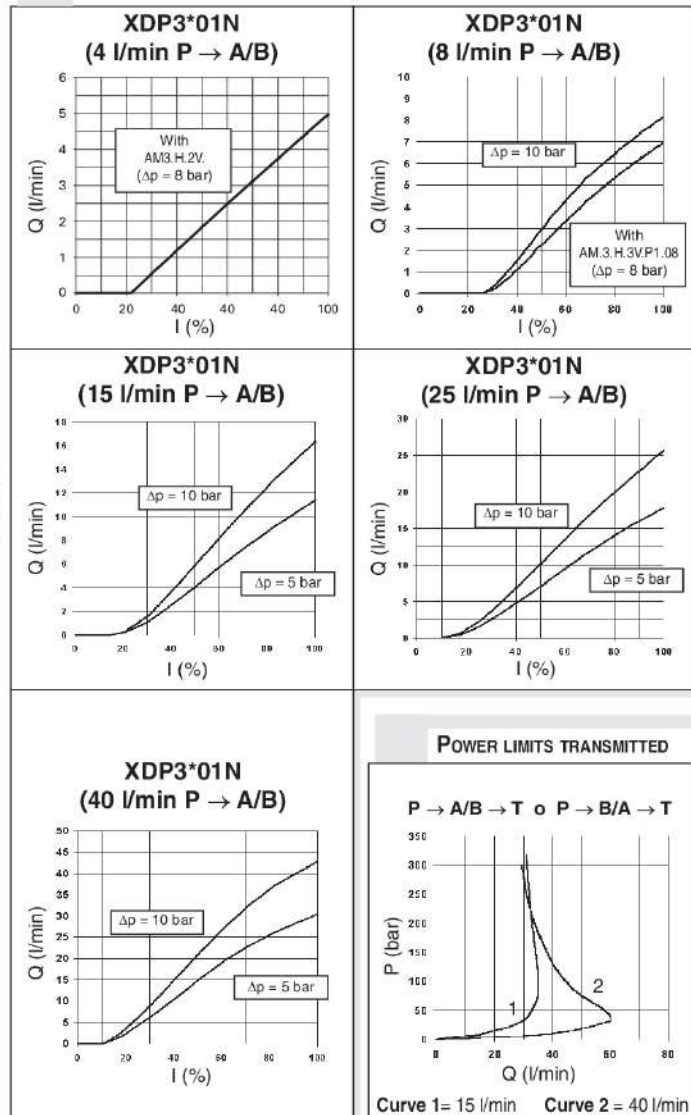

XDP3A... / XDP3C ... PROPORTIONAL DIRECTIONAL VALVES OPEN LOOP

OPERATING SPECIFICATIONS

Max. operating pressure ports P/A/B	350 bar		
Max. pressure port T - for dynamic pressure see note (*)	250 bar		
Nominal flow	8 / 15 / 25 / 40 l/min		
Duty cycle	Continuous 100% ED		
Type of protection (depending on the connector used)	IP 65		
Flow rate gain	See diagram		
Power limits curves transmitted	See diagram		
Fluid viscosity	10 ÷ 500 mm ² /s		
Fluid temperature	-20°C ÷ 75°C		
Ambient temperature	-20°C ÷ 70°C		
Max. contamination level	from class 7 at 9 in accordance with NAS 1638 with filter $\beta_{10} \geq 75$		
Weight XDP3A... (single solenoid)	1,7 Kg		
Weight XDP3C... (double solenoid)	2,9 Kg		
Max. current	2.35 A	1.76 A	0.88 A
Solenoid coil resistance 25°C (77°F)	2.25 Ohm	4.0 Ohm	16.0 Ohm
Hysteresis P / A / B / T with a pressure compensator AM.3.H.3V...	≤5%	<5%	<8%
Response to step $\Delta p = 5$ bar (P/A)			
0 ÷ 100%	32 ms	40 ms	85 ms
100% ÷ 0	33 ms	33 ms	33 ms
Frequency response -3db (Input signal 50% ±25% Vmax)			
	22Hz	22Hz	12Hz

(*) Pressure dynamic allowed for 2 millions of cycles

Operating specifications are valid for fluids with 46 mm²/s viscosity at 40°C, using the specified electronic control units. Performance data carried out using the specified power amplifier SE3AN... serie 1 - EUROCARD format - powered to 24V.

AMPLIFIER UNIT AND CONTROL

REMSRA** and REMDRA**

Electronic card control single and double proportional solenoid valve.
Recommended dither frequency 100 Hz.

AM3H2VP1 / AM3H3VP1 and AM5H3VP1 (*)

Hydrostats 2 or 3 way
(*) for rated flow XDP3 version at 40 l/min only

CONFIGURATION FOR DOUBLE FLOW RATE

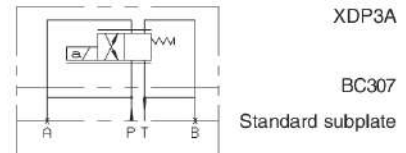

OVERALL DIMENSIONS

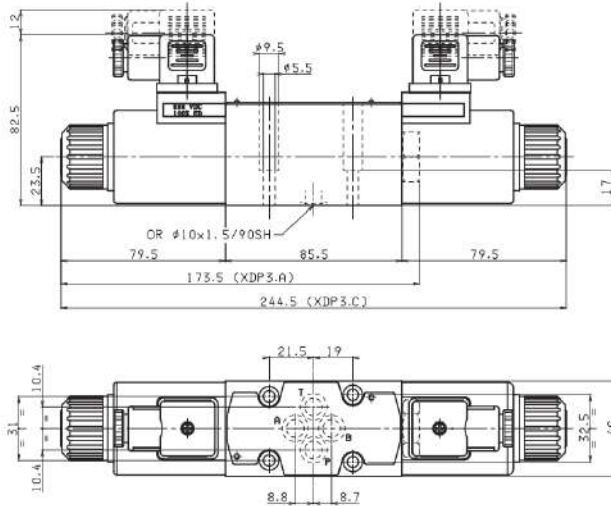

Fixing screws UNI 5931 M5x25
(min. 8.8 material screws are recommended)
Tightening torque 4 ÷ 5 Nm / 0.4 ÷ 0.5 Kgm

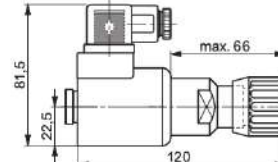
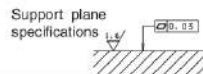

P2 Rotary emergency (1)

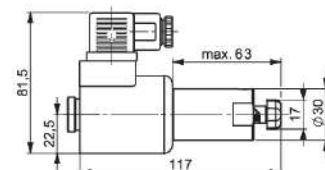

R5 Rotary emergency 180° (2)

- (1) P2 - Adjustable hand emergency.
- (2) R5 - Two positions hand emergency. The regulated flow with emergency actuated can be less than nominal value.

"D15P" PROPORTIONAL SOLENOIDS

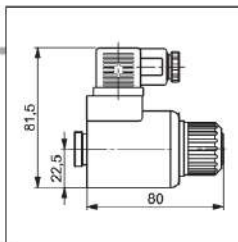

Type of protection (in relation to connector used)	IP 66
Duty cycle	100% ED
Insulation class wire	H
Weight (coil)	0,354 Kg
Weight (solenoid)	0,608 Kg



XDP5A... / XDP5C ...

PROPORTIONAL DIRECTIONAL VALVES OPEN LOOP

The open loop valves of series XDP control the direction and the volume of the flow according to the feeding current to the proportional solenoid.

Each Δp variation on the valve leads to the variation of the capacity which has been set, anyway the valve guarantees an high inner compensation grade and limits the adjustment capacity.

Performances shown in this catalogue are guaranteed only using 2 or 3 way modular assembly hydrostats type AM5H. ... (see note below in ordering code).

S5 variant - This variant that consists of a solenoid chamber drainage separated from the T line and obtained on CETOP RO5 interface allows operation with up to 320 bar max. back pressure on the T line. To ensure maximum solenoid valve mounting safety and supplementary drainage, only 12.9 material fixing screws must be used with it.

XDP5...	
STANDARD CONNECTORS	CAP. I • 20
"D19P" PROPORT. SOLENOIDS	CAP. VIII • 9
REMSRA...	CAP. IX • 4
REMDRA...	CAP. IX • 7
AM5H...	CAP. VIII • 16

ORDERING CODE

XDP	Open loop proportional directional valve
5	CETOP 5/NG10
*	A = Single solenoid C = Double solenoid
**	Type of spool (null position) <div style="display: flex; justify-content: space-around;"> <div style="text-align: center;"> 01 = </div> <div style="text-align: center;"> 03 = </div> </div>
N	Symmetrical flow path control (see hydraulic symbols table)
*	Flow rating (*) Δp 10 bar 2 = 45 l/min 3 = 60 l/min 5 = 100 l/min
*	Max. current to solenoid F = 2.5 A G = 1.25 A
**	Variants: see table 1
1	Serial No.

(*) Guaranteed with 24Volt, 2.5Amps supply.

TAB.1 - VARIANTS (**)

No variant (without connectors)	S1
Viton	SV
Rotary emergency	P2
External drainage	S5

(**) All variants are considered without connectors. The connectors must be order separately. See Cap. I • 20.

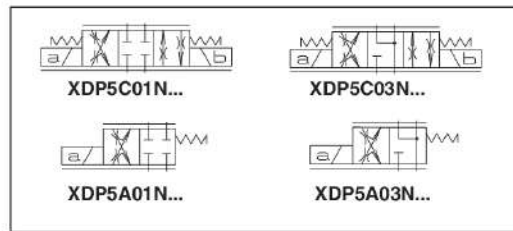

INPUT SIGNAL CURVES - FLOW RATE

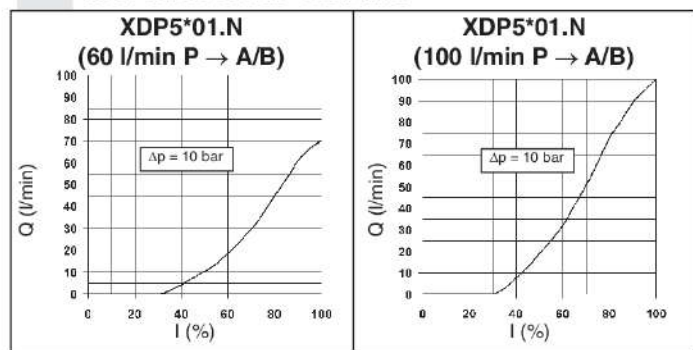

POWER LIMITS TRANSMITTED

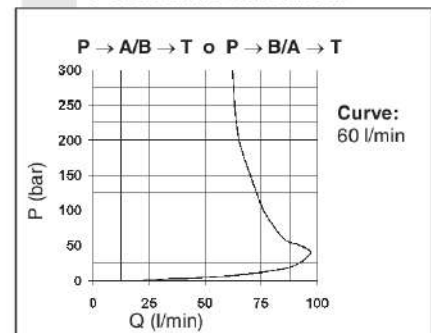

XDP5A... / XDP5C ... PROPORTIONAL DIRECTIONAL VALVES OPEN LOOP

OPERATING SPECIFICATIONS

Max. operating pressure ports P/A/B	320 bar
Max. pressure port T - for dynamic pressure see note (*)	250 bar
Max. pressure port T (with external drainage - S5 variant)	320 bar
Nominal flow	45 / 60 / 100 l/min
Duty cycle	Continuous 100% ED
Type of protection (depending on the connector used)	IP 65
Flow rate gain	See diagram
Power limits curves transmitted	See diagram
Fluid viscosity	10 ÷ 500 mm ² /s
Fluid temperature	-20°C ÷ 75°C
Ambient temperature	-20°C ÷ 70°C
Max. contamination level	from class 7 at 9 in accordance with NAS 1638 with filter $\beta_{10} \geq 75$
Weight XDP5A... (single solenoid)	4,97 Kg
Weight XDP5C... (double solenoid)	6,55 Kg

Max. current	2.5 A	1.25 A
Solenoid coil resistance 20°C (68°F)	2.85 Ohm	11.4 Ohm
Hysteresis P/A/B/T		
with a pressure compensator AM.5.H.3V...	<5%	<8%
Response to step $\Delta p = 10$ bar (P/A)		
0 ÷ 100%	56 ms	118 ms
100% ÷ 0	32 ms	32 ms
Frequency response -3db (Input signal 50% ±25% Vmax)		
	10Hz	7Hz

(*) Pressure dynamic allowed for 2 millions of cycles

Operating specifications are valid for fluids with 46 mm²/s viscosity at 40°C, using the specified electronic control units. Performance data carried out using the specified power amplifier type REMSRA... power supplied at 24V.

AMPLIFIER UNIT AND CONTROL

REMSRA. and REMDRA**.:**
Electronic card control single and double proportional solenoid valve.
Recommended dither frequency 100 Hz.

AM5H2VP1 / AM5H3VP1(Δp=10bar)
Hydrostats 2 or 3 way.

OVERALL DIMENSIONS

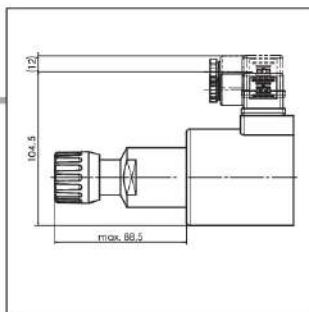
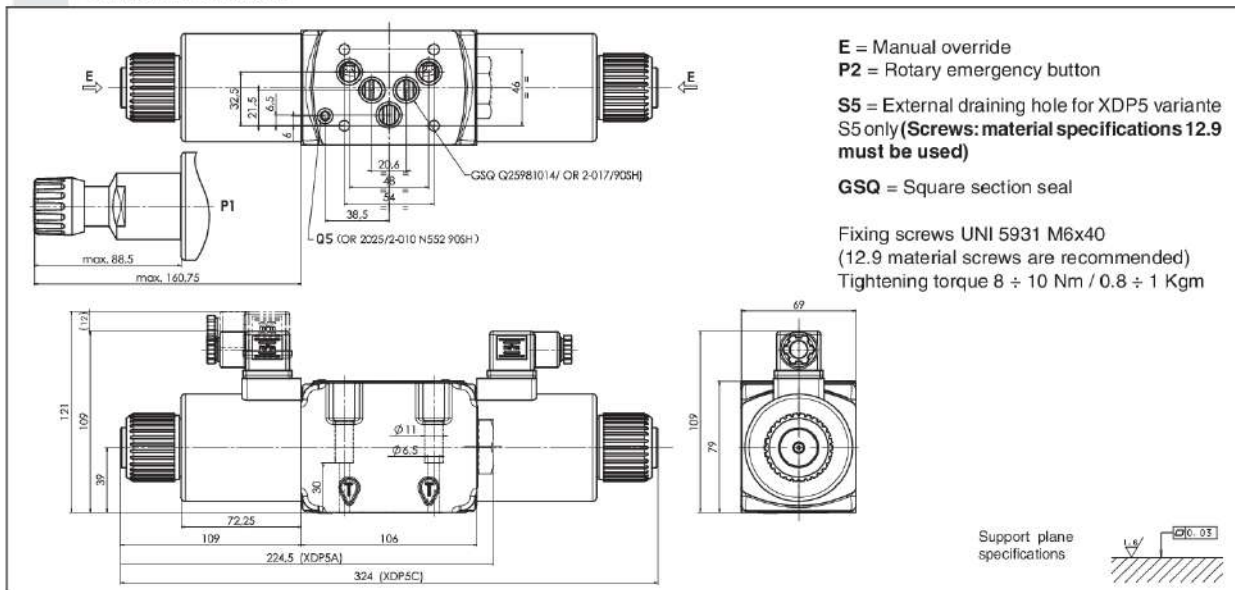

"D19P" PROPORTIONAL SOLENOIDS

Type of protection (in relation to connector used)	IP 65
Ambient temperature	-25°C ÷ 60°C
Duty cycle	100% ED
Insulation class wire	H
Weight	1,58 Kg



XDC3... PROPORTIONAL DIRECTIONAL VALVES

CLOSED LOOP POSITION CONTROL

The valves XDC serie 2 control the direction and the volume of the flow according to the feeding current to the proportional solenoid. The position transducer type LDVT (inductive position transducer) monitors the actual position of the spool.

In the electronic card (type SE.AN.21.RS...serie 3) the error between the actual position and the reference signal is used to obtain a greater precision of the spool positioning, reducing also considerably the hysteresis and the repeatability error of the valve. For a more accurate flow control, 2 or 3-way pressure compensators modular plate design are available.

The shown flow rates are typical for one line operation (e.g. from P to B). By using the valve with the base for capacity doubling type BC.3.07 greater capacity can be obtained.

XDC3...2	
STANDARD CONNECTORS	CAP. I • 20
PROPORTIONAL SOLENOID	CAP. VIII • 11
SE3AN21RS...3	CAP. IX • 11
AM3H...	CAP. VIII • 15
AM5H...	CAP. VIII • 16
BC307...	CAP. VII • 12

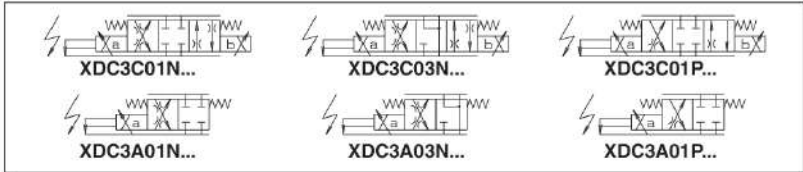

CE Registered mark for industrial environment with reference to the electromagnetic compatibility.

European norms: EN50082-2 - general safety norm - industrial environment; EN50081-1 - emission general norm - residential environment

ORDERING CODE

XDC	Proportional directional valve with closed loop position control
3	CETOP 3/NG6
*	A = Single solenoid C = Double solenoid
**	Type of spool (null position) 01 = 03 =
*	Flow path control (see hydraulic symbols) N = symmetrical P = meter in (only with 01 spool)
*	Flow rating l/min (Δp 10 bar) A = 4 l/min 1 = 8 l/min 2 = 15 l/min 3 = 25 l/min 6 = 40 l/min In order to reduced the unloading pressure for rated flow version at 40 l/min we advise to use the 3 way type AM5H3V... hydrostat.
F	Max. current at solenoid: 1.76 A
S1	No variant (without connectors)*
2	Serial No.

Notice:
in order to control the valve XDC3...serie 2 it need to use the electronic card SEAN21RS...serie 3, in exclusive way (See Ch. IX).

(* All variants are considered without connectors. The connectors must be order separately. See Cap. I • 20.

INPUT SIGNAL CURVES - FLOW RATE

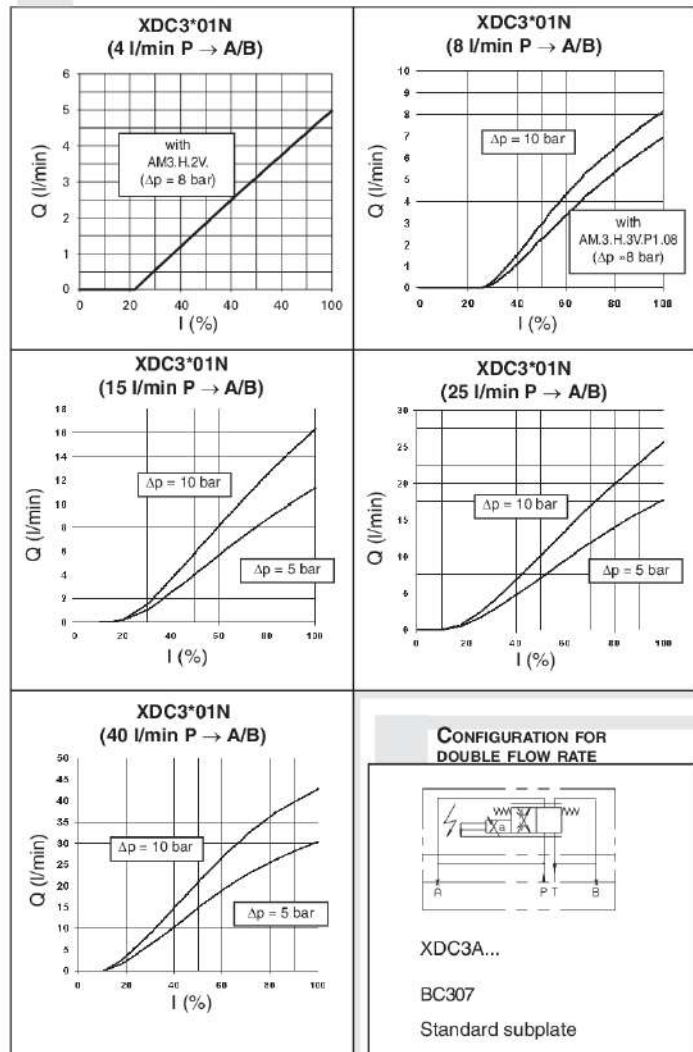

XDC3... PROPORTIONAL DIRECTIONAL VALVES CLOSED LOOP POSITION CONTROL

OPERATING SPECIFICATIONS OF VALVE WITH TRANSDUCER

Max. operating pressure ports P/A/B	350 bar
Dynamic pressure port T	210 bar
Static pressure port T	210 bar
Nominal flow	8 / 15 / 25 / 40 l/min
Duty cycle	Continuous 100% ED
Type of protection (depending on the connectors used)	IP 65
Performance curves	See diagrams
Fluid viscosity	10 ÷ 500 mm ² /s
Fluid temperature	-20°C ÷ 75°C
Ambient temperature	-20°C ÷ 70°C
Max. contamination level	class 7 to 9 in accordance to NAS 1638 with filter B ₁₀ >75
Weight XDC3A... (single solenoid)	1,94 Kg
Weight XDC3C... (double solenoid)	2,55 Kg
Max. current	1.76 A
Solenoid coil resistance at 20°C (68°F)	4.55 Ω
Solenoid coil resistance when hot	7.34 Ω
Hysteresis P/A/B/T with pressure compensator AM3H3V...	<1%
Transient function with stepped electrical input signals Δp = 5 bar (P/A)	
0 ÷ 100%	65 ms
100% ÷ 0	75 ms
Repeatability	<0,5%
Frequency response -3db (Input signal ±25% Vmax)	10 Hz
Insulation class wire	H
Weight of solenoid	0,6 Kg

Operating specifications are valid for fluids with 46 mm²/s viscosity at 40°C, using the SE3AN21RS... serie 3 electronic control unit powered to 24V.

AMPLIFIER UNIT AND CONTROL

SE3AN21RS...serie 3 - Electronic card EURO-CARD format for control of the proportional valve equipped with transducer

**AM3H2VP1 / AM3H3VP1
AM5H3VP1 (*)**

Hydrostats 2 or 3 way

(*) for rated flow XDC3 version at 40 l/min) only

TRANSDUCER ELECTRICAL CONNECTIONS

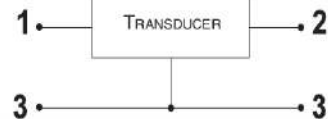

1 = Supply 18VDC ÷ 36VDC
3 = Mass
2 = Output 2V ÷ 10V

POSITION TRANSDUCER SPECIFICATION

Electrical measuring system	LVDT
Nominal stroke	6 mm
Electrical connection	M12x1
Insulation (depending on the connector used)	IP65
Frequency response	500 Hz
Linearity tolerance	±1%

PROPORTIONAL SOLENOID

OVERALL DIMENSIONS

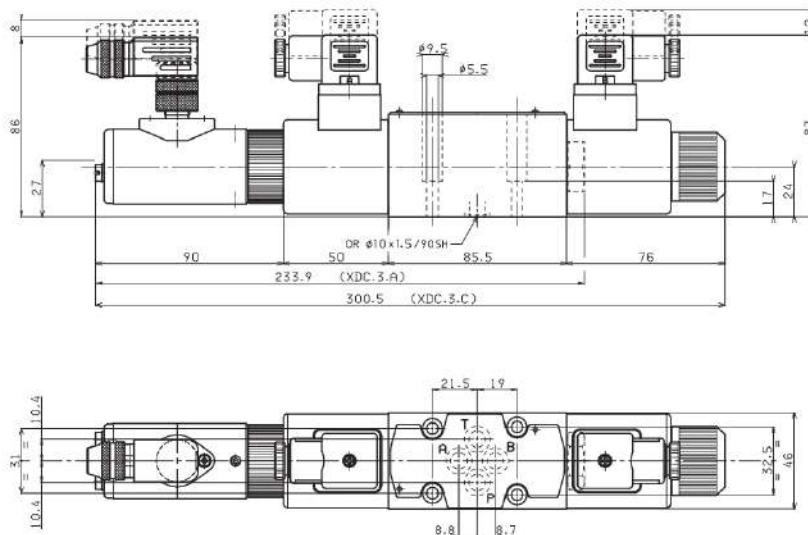

Fixing screws UNI 5931 M5x25
(min. 8.8 material screws are recommended)
Tightening torque 4 ÷ 5 Nm / 0.4 ÷ 0.5 Kgcm

Support plane specifications

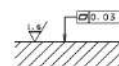

8

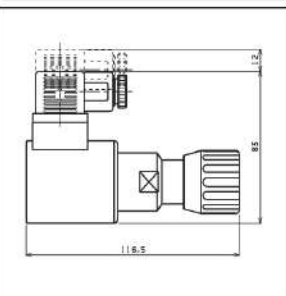
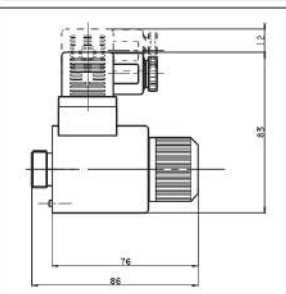



XEPV3... PROPORTIONAL VALVE WITH ELECTRONIC ON BOARD

The proportional directional valves XEPV are designed as direct operated components for subplate mounting. They are actuated by means of proportional solenoids with central thread and removable coil. The solenoids are controlled by integrated control electronics.

Features:

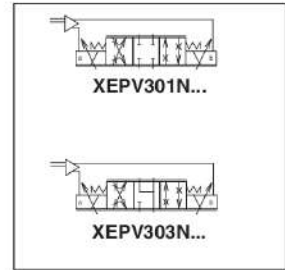

- Integrated control electronics
- Setup parameters by CAN interface
- Current compensation, gain current and ramps setting
- Monitoring of the valve by real time scope interface

European norms: EN 61000 - ElectroMagnetic Compatibility (EMC) - industrial environment



XEPV3...	
AM3H...	CAP. VIII • 15
AM5H...	CAP. VIII • 16
BC307...	CAP. VII • 12

ORDERING CODE

XEPV	Current loop proportional valve with integrated electronics 24Vdc
3	CETOP 3/NG6
**	Type of spool
01	 spool with P, A, B and T ports, closed
03	 spool with P port closed, and A, B, T ports connected
N	Symmetrical flow control
*	Flow rating at ΔP 8 bar
	0 = 4 l/min
	1 = 8 l/min
	2 = 15 l/min
	3 = 25 l/min
	6 = 36 l/min (we advise to use the hydrostat AM5H3VP108)
S	CAN bus communication
	S = standard
W	Command Enable
	W = without external command Enable
*	Type command
	V = signal voltage $\pm 10V$
	C = signal current 4... 20mA
00	No variants
1	Serial No.

INPUT SIGNAL CURVES - FLOW RATE

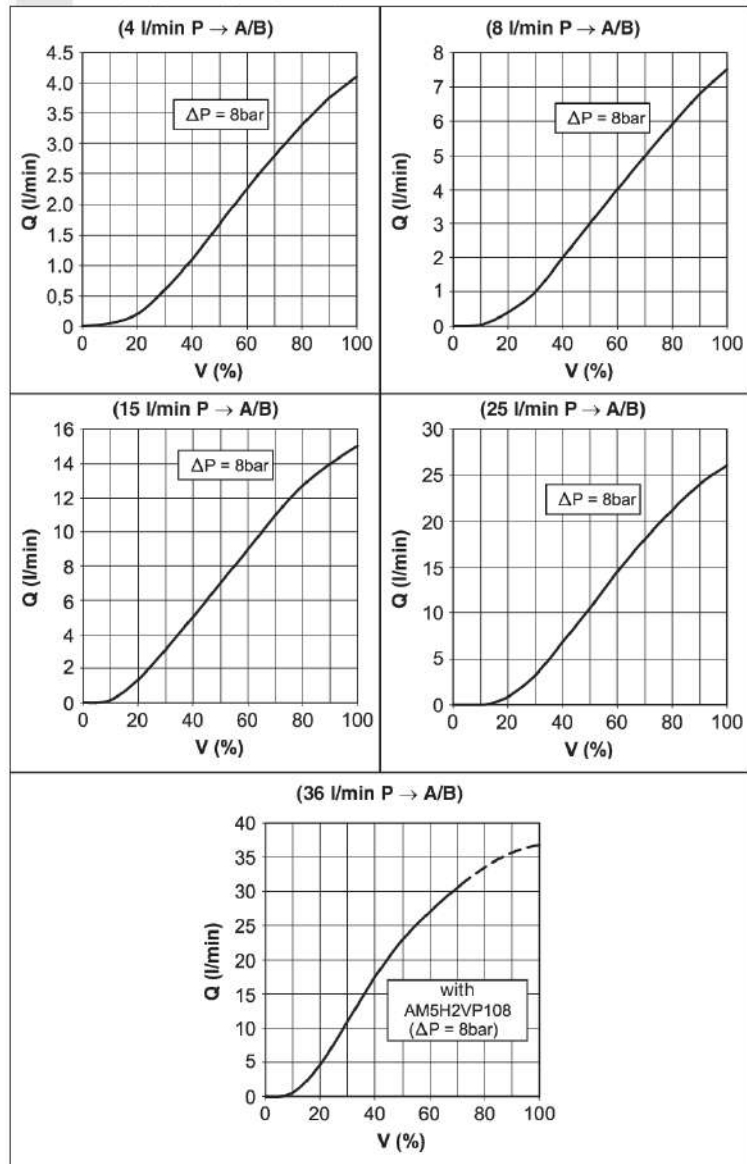

XEPV3... PROPORTIONAL VALVE WITH ELECTRONIC ON BOARD

STEP RESPONSE ($\Delta p = 8$ bar P/A)

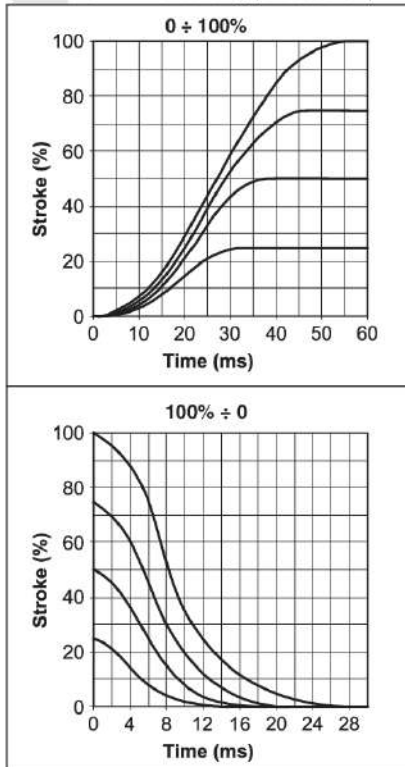

OPERATING SPECIFICATIONS OF VALVE WITH TRANSDUCER

Installation	must keep horizontal
Max. operating pressure ports P/A/B	350 bar
Dynamic pressure port T	210 bar
Static pressure port T	210 bar
Nominal flow	4 / 8 / 15 / 25 / 36 l/min
Performance curves	See diagrams
Fluid temperature	-20 ÷ 75°C (preferably 40 ÷ 50°C)
Fluid viscosity	10 ÷ 500 mm ² /s
Max. contamination level	class 7 to 9 in accordance to NAS 1638 with filter $\beta_{10} \geq 75$
Weight	2.45 kg
Nominal supply voltage	24Vdc
Input signal range (see ordering code)	± 10V or 4...20mA
Supply voltage lower limit	18V
Supply voltage upper limit	30V
Peak power	50W
Max. coil temperature	150 °C
Duty cycle	Continuous 100% ED
Hysteresis	< 5%
Response sensitivity	< 0.5%
Repeatability	< 0.5%
Fault signal output	0V = failure or not working valve 24V = valve OK
Current monitor	± 10V
Ambient temperature range	-20 ÷ 60°C
Type of protection	IP 65

Operating specifications are valid for fluids with 46 mm²/s viscosity at 40°C.

OVERALL DIMENSIONS

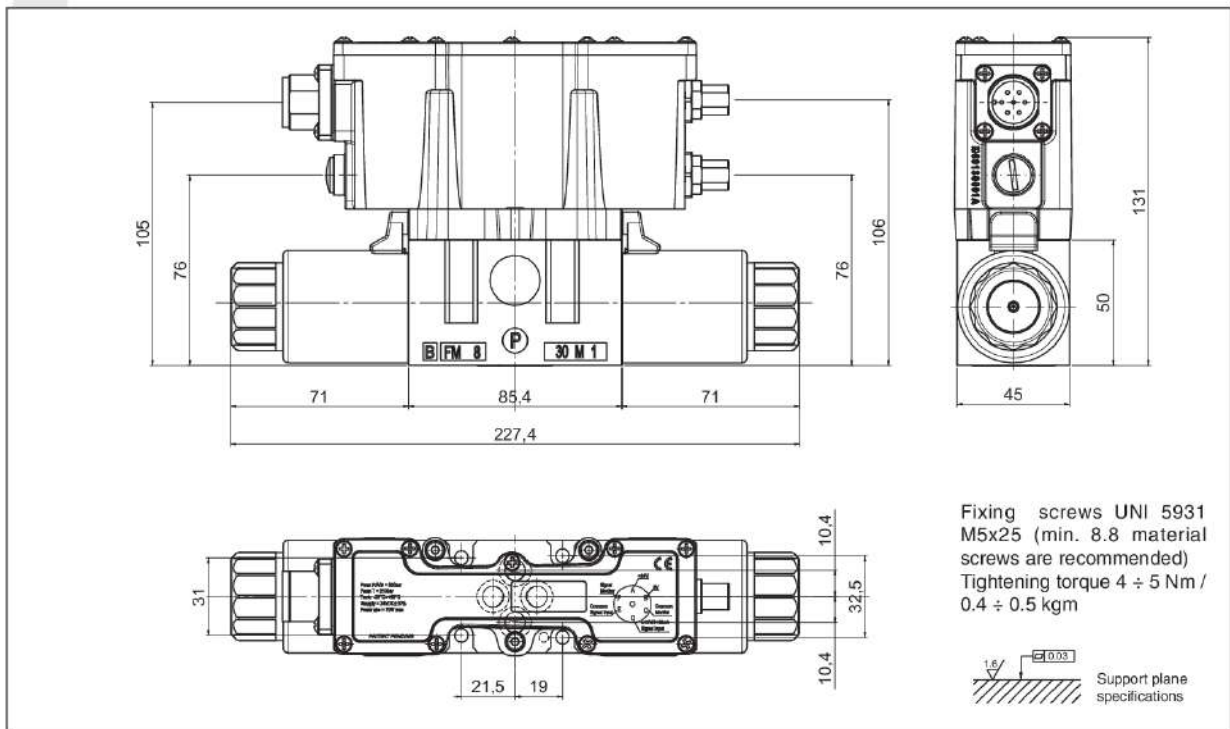

XEPV3... PROPORTIONAL VALVE WITH ELECTRONIC ON BOARD

ELECTRICAL CONNECTIONS

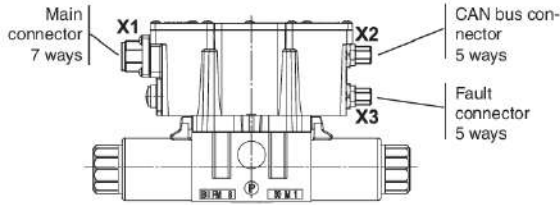

- A positive command value 0 to +10V (or 12 to 20mA) at D and the reference potential at E, results in a flow from P to A and B to T.
- A negative command value 0 to -10V (or 12 to 4mA) at D and the reference potential at E, results in a flow from P to B and A to T.

X1: Main connector 7 ways (supplied with the valve)

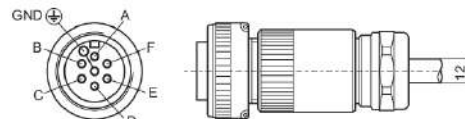

DIN EN 175201-804 - 7 poles female

Type	PIN	Description
Main power supply	A	+24Vdc
	B	0V / common supply
0V / common of signal monitor	C	0V / common of signal monitor
Input of differential signal command	D	± 10V or 4...20mA
	E	0V / common
Output of signal monitor	F	± 10V (10V = max current)
	GND	GND

Connection cable recommended: up to 50m cable length type LiYCY 7x1.0 mm². For outside diameter see plug-in connector sketch. Only connect screen to PE on the supply side.

X2*: 5 ways M12 connector, CAN communication (to be ordered separately)

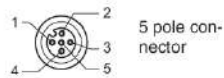

5 pole connector

5 ways connector code: VE0032700

IEC 61076-2-101 - 5 poles female

Type	PIN	Description
CAN data interface	1	CAN_H
	2	CAN_L
	3	
	4	
	5	GND

* Connection cable recommended: up to 50m cable length type LiYCY 7x0.75 mm². For outside diameter see plug-in connector sketch. Only connect screen to PE on the supply side.

X3*: 5 ways M12 connector - Fault digital command (to be ordered separately)

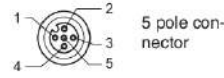

5 pole connector

5 ways connector code: VE0032700

IEC 61076-2-101 - 5 poles female

Type	PIN	Description
Digital output signal of valve FAULT	1	Connects to +24Vdc
	2	Signal out: 0V = failure of electronic control 24V = valve OK
	3-4-5	Not used

8

SOFTWARE AND CABLES

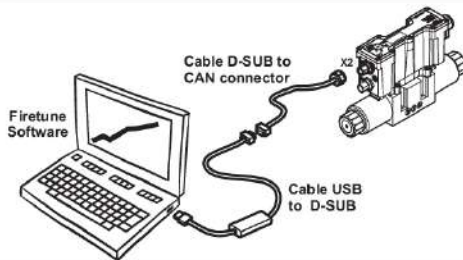

INTERFACE FOR SETUP PARAMETERS

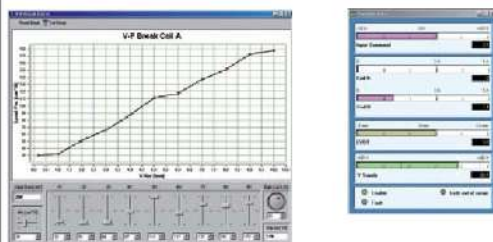

Firetune software code: P35150005

For further information about Firetune read the manual. The software is included with valve supply.

ADAPTER FOR PC: CABLE USB TO D-SUB



Model: KVASER Leaf light HS (not supplied, commercial parts)

ADAPTER FOR PC: CABLE D-SUB TO CAN CONNECTOR

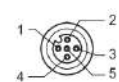

CAN connector

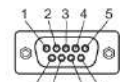

D-Sub connector (female)

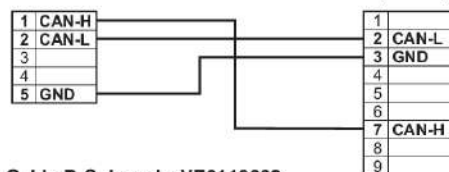

Cable D-Sub code: VE0110002



AM3H...

AM3H... 2 AND 3 WAY HYDROSTATS CETOP 3

The 2 or 3 way pressure regulator type AM3H ensure the constant set flow rate in the presence of varying system load (pressure) by keeping constant the pressure drop ($\Delta p = 4/8$ bar) in relation to the flow rate regulation.

In order to achieve the direction and flow rate dual control function, it is normally used together with a proportional solenoid valve

Max. flow	25 l/min
Max. operating pressure	350 bar
Δp adjustment	4 bar 8 bar
Fluid viscosity	$10 \div 500$ mm ² /s
Fluid temperature	-25°C ÷ 75°C
Ambient temperature	-25°C ÷ 60°C
Max. contamination level class 8 in accordance with NAS 1638 with filter $\beta_{10} \geq 75$	
Weight	1,4 Kg

ORDERING CODE

AM	Modular valve
3	CETOP 3/NG6
H	Hydrostat
**	2V = 2 way 3V = 3 way
P1	Function at port P
**	Differential pressure (Δp) 04 = Δp 4 bar 08 = Δp 8 bar
**	00 = No variant V1 = Viton
2	Serial No.

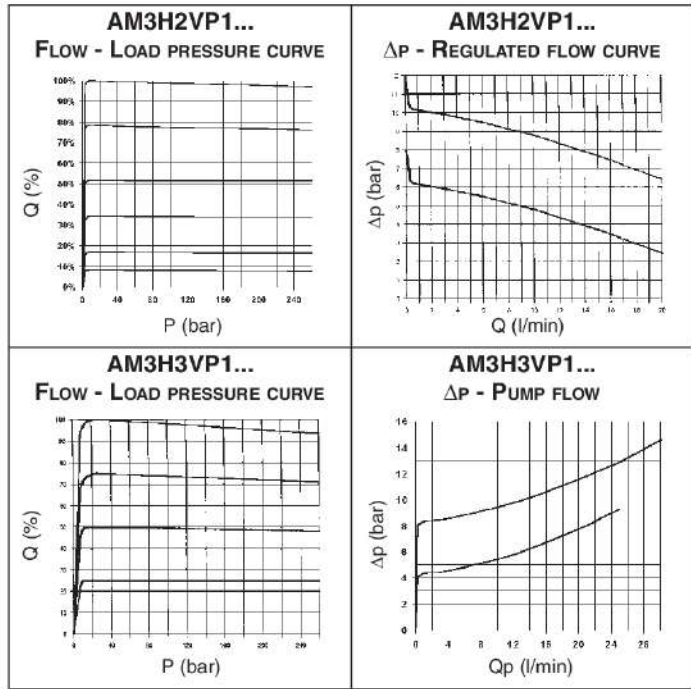
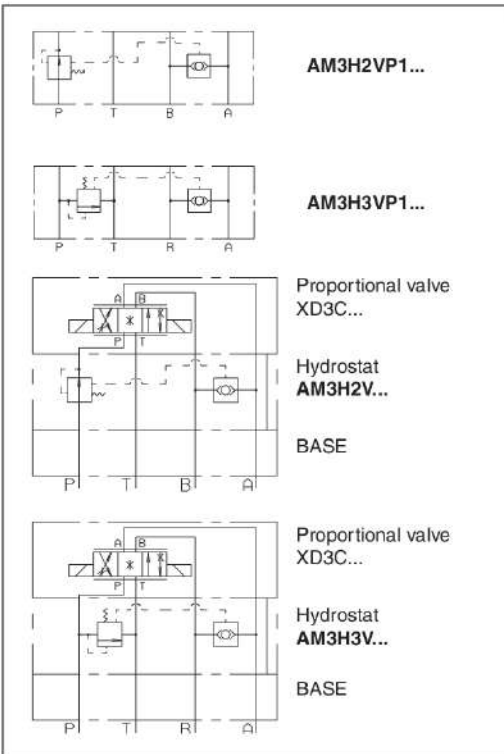

8

OVERALL DIMENSIONS

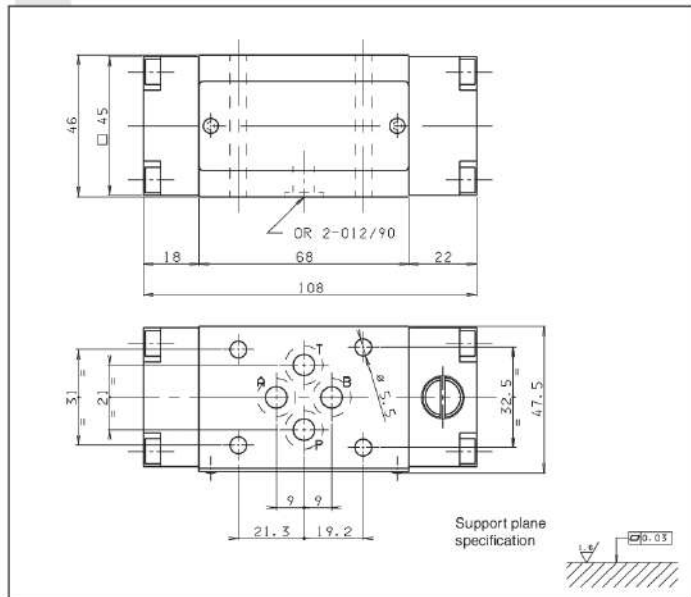



AM5H...

AM5H... 2 AND 3 WAY HYDROSTATS CETOP 5

The 2 or 3 way pressure regulator type AM5H ensures a constant set flow rate in the presence of varying system load (pressure) by keeping constant the pressure drop ($\Delta p=8$ bar) in relation to the flow rate regulation. In order to achieve the direction and flow rate dual control function, it is normally used together with a proportional solenoid valve.

Max. flow AM5H2V...	65 l/min
Max. flow AM5H3V...	70 l/min
Max. operating pressure	350 bar
Δp adjustment	8 bar
Fluid viscosity	$10 \div 500 \text{ mm}^2/\text{s}$
Fluid temperature	$-25^\circ\text{C} \div 75^\circ\text{C}$
Ambient temperature	$-25^\circ\text{C} \div 60^\circ\text{C}$
Max. contamination level class 8 in accordance with NAS 1638 with filter $\beta_{10} \geq 75$	
Weight	2,7 Kg

ORDERING CODE

AM	Modular valve
5	CETOP 5/NG10
H	Hydrostat
**	2V = 2 way 3V = 3 way
P1	Function at port P
08	Differential pressure (Δp) Δp 8 bar
**	00 = No variant V1 = Viton
2	Serial No.

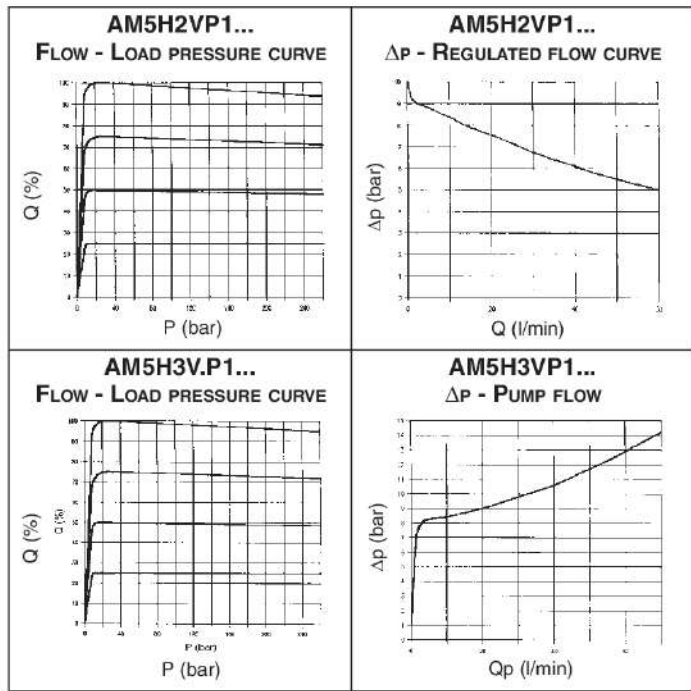

8

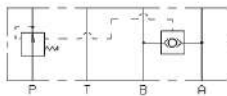

AM5H2VP1...

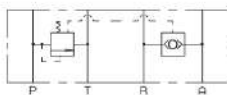

AM5H3VP1...

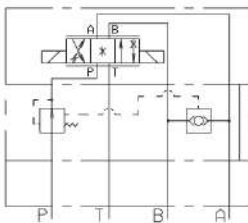

Proportional valve
XD5C...

Hydrostat
AM5H2V...

BASE

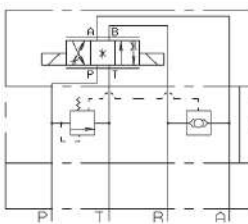

Proportional valve
XD5C...

Hydrostat
AM5H3V...

BASE

OVERALL DIMENSIONS

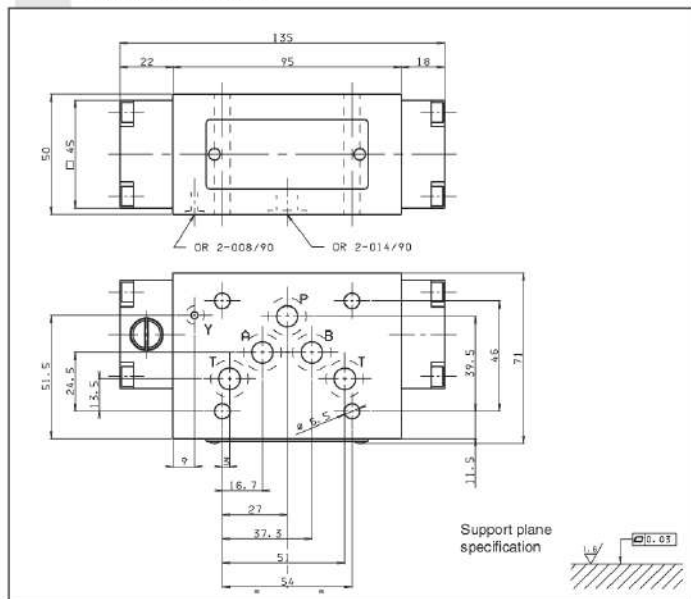



XQ3... PROPORTIONAL FLOW CONTROL VALVES PRESSURE COMPENSATED CETOP 3

This is a proportional valve where both the flow rate and pressure control flow functions have been integrated according to the 3 way regulation concept.

The interface UNI ISO 4401 - 03 - 02 - 0 - 94 standard (ex CETOP R 35 H 4.2-4-03) allows for direct mounting on modular block or multiple sub-bases, which makes possible many advantageous and extremely compact application solution as a consequence of their simplicity of installation.

The 3 way type pressure compensator, inserted into the valve, holds the pressure drop across the flow rate proportional regulator constant (approx. 8 bar) independently from the controlled load variations, whereby ensuring proportional between the set flow rate and the electrical command signal.

Additionally, the system maximum safety pressure can be regulated through a manual command. This valve, if mounted on the feed line to the manifold block, can be used to control several circuits which are not operating at the same time.

XQ3...	
STANDARD CONNECTORS	CAP. I • 20
"D15P" PROPORT. SOLENOIDS	CAP. VIII • 18
REMSRA...	CAP. IX • 4
BC308. / BC309. / BC06XQ3.	CAP. VII • 13

ORDERING CODE

XQ	Proportional flow control valve
3	No. of way
C	Pressure compensation
3	CETOP 3/NG6
*	Flow rates F = 5 l/min G = 10 l/min H = 16 l/min I = 28 l/min
*	M = With manual pressure limiter S = Without manual pressure limiter
*	Setting ranges 1 = 8 ÷ 50 bar 2 = 25 ÷ 170 bar 3 = 50 ÷ 315 bar Omit for XQ3C*S version
*	E = With rotary emergency (type P2) S = Without rotary emergency
*	Voltage E = 9VDC (2,35 A) F = 12VDC (1.76 A) G = 24VDC (0.88 A)
**	Variant (*):
2	Serial No.

TAB.1 - VARIANTS (*)

No variant (without connectors)	S1
Viton	SV
Emergency lever	L5
Rotary emergency 180°	R5

(*) All variants are considered without connectors. The connectors must be order separately. See Cap. I • 20.

DIAGRAMS

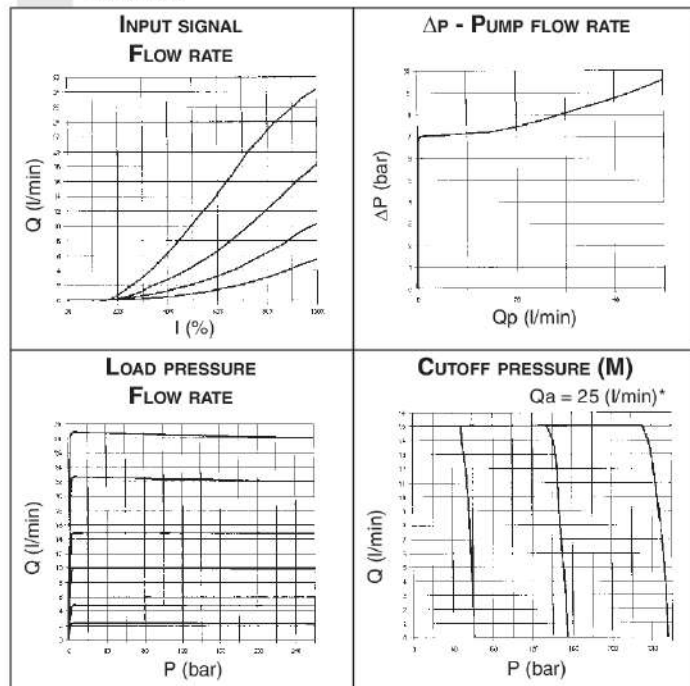

The fluid used is a mineral based oil with a viscosity of 46 mm²/s at 40°C. The tests have been carried out at with a fluid of a 40°C. (*) Tested with 25 l/min supply

TABLE 1 - FLOW / PRESSURE SPECIFICATIONS

Model	Hydraulic symbol	Max flow rate (l/min)	Max flow in P (l/min)	Max limiter pressure (bar)	Max load pressure (bar)	Δp Control (bar)
XQ3C3*M		5	40	8÷50	250	8
		10		25±170		
		16		50±315		
		28				
XQ3C3*S		5	40		250	8
		10				
		16				
		28				

XQ3... PROPORTIONAL FLOW CONTROL VALVES PRESSURE COMPENSATED

Max. operat. pressure ports A/B / With P port blocked on subplate	315 bar
Max. operating pressure ports T - for dynamic pressure see note (*)	250 bar
Regulated flow rate	See diagram page before
Relative duty cycle	Continuous 100% ED
Type of protection	IEC 144 class IP 65
Flow rate gain	See diagrams
Hysteresis with connection P/A/B/T $\Delta p = 5$ bar (P/A)	$\leq 4\%$ of max. flow rate
Fluid viscosity	$10 \div 500$ mm ² /s
Fluid temperature	$-20^{\circ}\text{C} \div 75^{\circ}\text{C}$
Max. contamination level	class 8 in accordance with NAS 1638 with filter $\beta_{0.5} \geq 75$
Weight version XQ3C*M...	2,89 Kg
Weight version XQ3C*S...	2,39 Kg

Type of voltage	9V	12V	24V
Max. current	2.35A	1.76 A	0.88 A
Solenoid coil resistance at 25°C (77°F)	2.25 Ohm	4.0 Ohm	16.0 Ohm

(*) Pressure dynamic allowed for 2 millions of cycles.

ELECTRONIC CONTROL UNIT

REMSRA**

Card type control for single solenoid.
Recommended dither frequency 100 Hz.

SE3AN2100...

EUROCARD type control for single solenoid

• Operating specifications are valid for fluid with 46 mm²/s viscosity at 40°C, using the specified electronic control units

TYPICAL INSTALLATION

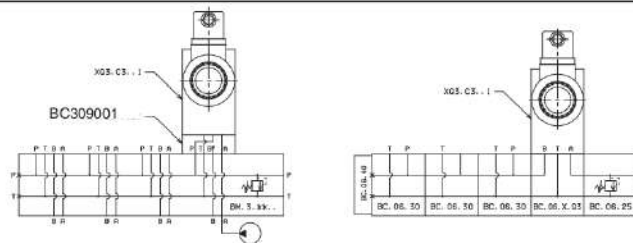

OVERALL DIMENSIONS

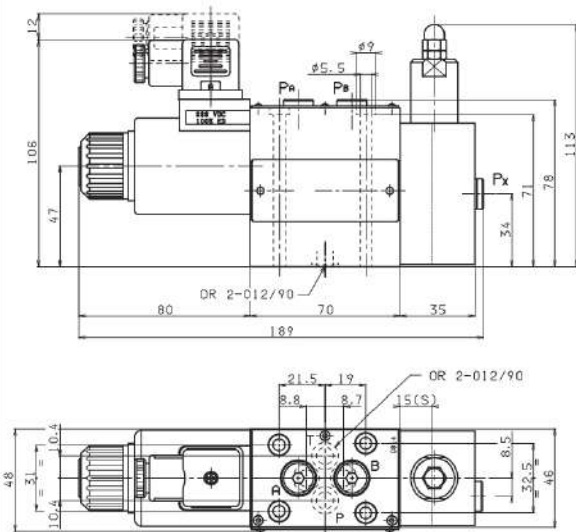

Fixing screws UNI 5931 M5x80 (min. 8.8 material screws are recommended)
Tightening torque $4 \div 5$ Nm / $0.4 \div 0.5$ Kgm

Support plane specification

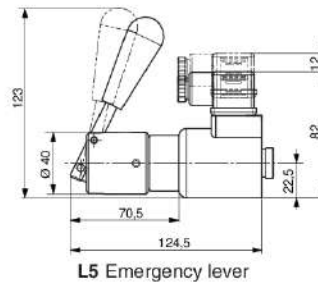
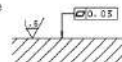

L5 Emergency lever

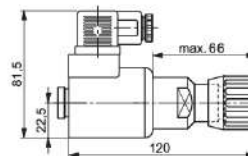

Rotary emergency version XQ3C3**E

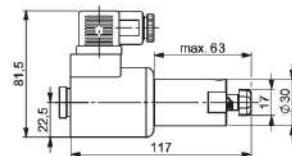

R5 Rotary emergency 180°(1)

(1) Two positions hand emergency. The regulated flow with emergency actuated can be less than nominal value.

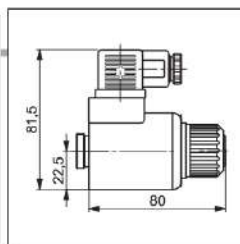

"D15P" PROPORTIONAL SOLENOIDS

Type of protection (in relation to connector used)	IP 66
Duty cycle	100% ED
Insulation class wire	H
Weight (coil)	0,354 Kg
Weight (solenoid)	0,608 Kg



XQP3... OPEN LOOP 2/3 WAY PROPORTIONAL PRESSURE COMPENSATED FLOW REGULATORS

The open loop proportional flow regulator is 2 and 3 way compensated with priority function. It is designed to regulate flow in proportion to an applied electrical current (REM or SE3AN power amplifier). Flow regulation is load independent - B port. Load compensation is achieved by a spool compensator which holds the pressure drop constant across the proportional spool.

Valves are available in the following versions (see hydraulic symbol):

- 2 way pressure compensated - 3 way pressure compensated with priority function.
- 3 way pressure compensated with priority and venting function.

XQP3...	
STANDARD CONNECTORS	CAP. I • 20
"D15P" PROPORT. SOLENOIDS	CAP. VIII • 20
REMSRA...	CAP. IX • 4
BC06XQP3...	CAP. VII • 13

ORDERING CODE

XQP	Open loop 2/3 way proportional compensated flow regulator
3	CETOP 3/NG6
C	2/3 way compensation with priority function
3	3 way version (standard) For to obtain 2-way version the P line must be closed on the subplate
*	Nominal flow rates F = 6 l/min G = 12 l/min H = 22 l/min I = 32 l/min L = 40 l/min
*	S = without decompression D = with decompression
*	Max. current to solenoid E = 2.35 A F = 1.76 A G = 0.88 A
**	Variants (*): S1 = No variant P2 = Rotary emergency R5 = Rotary emergency 180° SV = Viton
2	Serial No.

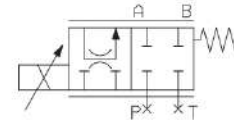

• In order to obtain the 2 way pressure compensated version the cavities P and T have be closed on the subplate.

HYDRAULIC SYMBOLS

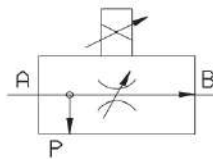

• In order to obtain the 3 way pressure compensated version the cavity T have be closed on the subplate.

DIAGRAMS

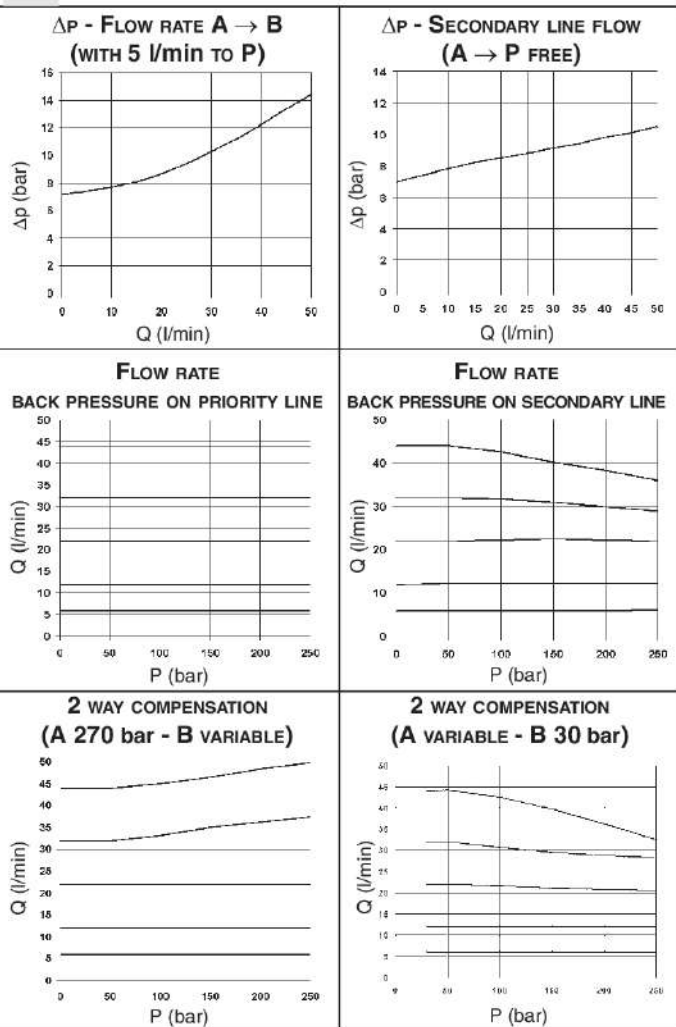

(* All variants are considered without connectors. The connectors must be order separately. See Cap. I • 20.

The fluid used is a mineral based oil with a viscosity of 46 mm²/s at 40°C. The tests have been carried out at with a fluid of a 40°C.

XQP3... OPEN LOOP 2/3 WAY PROPORTIONAL PRESSURE COMPENSATED FLOW REGULATORS

OPERATING SPECIFICATIONS

Max. operat. pressure ports A/B/P see note (*) With T port blocked on subplate	250 bar		
Regulated flow rate	6 / 12 / 22 / 32 / 40 l/min		
Decompression drain flow	max 0,7 l/min		
Relative duty cycle	Continuous 100% ED		
Type of protection (in relation to the connector used)	IP 65		
Flow rate gain	See diagram "Input signal flow"		
Fluid viscosity	10 ÷ 500 mm ² /s		
Fluid temperature	-20°C ÷ 75°C		
Ambient temperature	-20°C ÷ 70°C		
Max. contamination level	from class 7 to 9 in accordance with NAS 1638 with filter $\beta_{10} \geq 75$		
Weight	1,7 Kg		

Max. current	2.33A	1.76 A	0.88 A
Solenoid coil resistance at 25°C (77°F)	2.25 Ohm	4.0 Ohm	16.0 Ohm
Hysteresis with Δp 7 bar	$\leq 5\%$	$< 5\%$	$< 8\%$
Response to step $\Delta p = 7$ bar			
0 ÷ 100%	32 ms	40 ms	85 ms
100% ÷ 0	33 ms	33 ms	33 ms
Frequency response -3db (Input signal 50% \pm 25% Vmax.)	22Hz	22Hz	12Hz

(*) Pressure dynamic allowed for 2 millions of cycles

Operating specifications are valid for fluids with 46 mm²/s viscosity at 40°C, using specified electronic control units.

Performance data are carried out using the specified power amplifier SE3AN... powered to 24V.

AMPLIFIER UNIT AND CONTROL

REMSRA**...

Electronic card for control single proportional solenoid valve.
Recommended dither frequency 100 Hz.

OVERALL DIMENSIONS

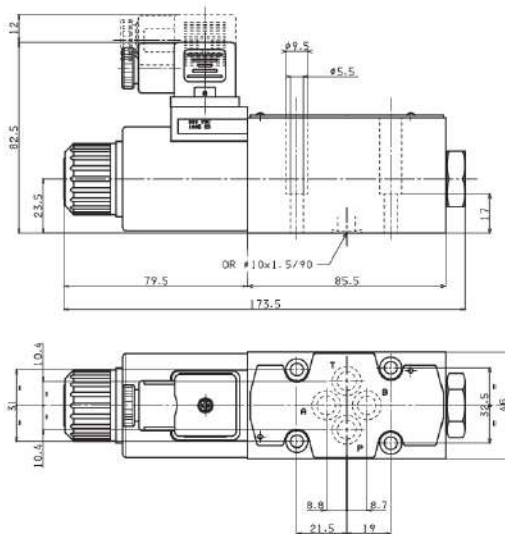

Fixing screws UNI 5931 M5x25
(min. 8.8 material screws are recommended)
Tightening torque 4 ÷ 5 Nm / 0.4 ÷ 0.5 Kgm

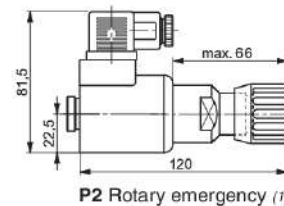
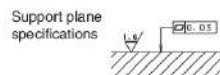

P2 Rotary emergency (1)

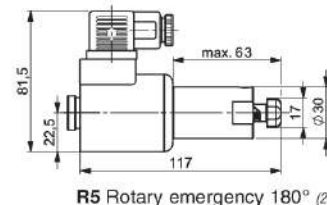

R5 Rotary emergency 180° (2)

- (1) P2 - Adjustable hand emergency.
(2) R5 - Two positions hand emergency. The regulated flow with emergency actuated can be less than nominal value.

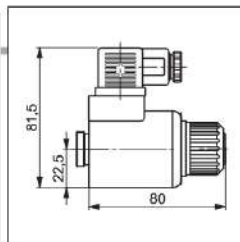

"D15P" PROPORTIONAL SOLENOIDS

Type of protection (in relation to connector used)	IP 66
Duty cycle	100% ED
Insulation class wire	H
Weight (coil)	0,354 Kg
Weight (solenoid)	0,608 Kg