

Inlet section Open Centre and Closed Centre

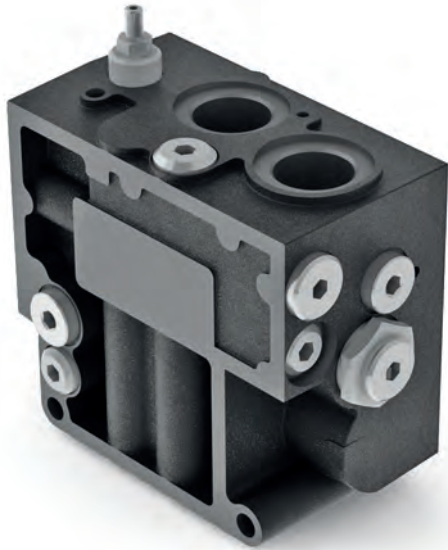

Standard HSE inlet sections

The inlet sections are available in two versions:

- **open centre for use with fixed displacement pumps**
- **closed centre for use with load-sensing pumps**

In the **open centre** versions, when the spool is not working, the flow/ pressure regulator - pos. 1 - unloads to T the entire pump flow (see characteristic curves).

Otherwise, when the spool is working, it will feed the controlled element or elements, adapting instantaneously to the actual flow required by the ports and unloading any excess flow at the highest pressure of that moment to the tank.

By changing two internal pilot lines, the section is converted into a **closed centre** version. In the closed centre versions, the regulator - pos. 1 - only maintains the pressure regulator function, becoming the first stage of the main pressure relief valve pos. 2, which must be calibrated to about 30 bar [435 psi] more than the maximum work pressure.

Both versions can be supplied with the pressure reduction valve - pos. 3 - where originates a low pressure line (18-22 bar - 261 ÷ 319 psi) that feeds the MHPED electrohydraulic modules or also the same hydraulic manipulators. Obviously, if the valve is only equipped with manual control, the pressure reduction valve is not required.

HPV 41

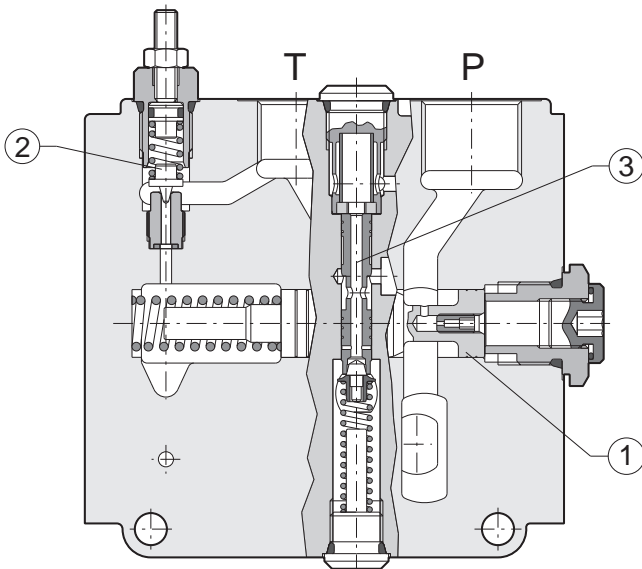

Standard HSE inlet section

1	3 way flow regulator
2	Pilot pressure relief valve
3	Pressure reduction valve
Lp	Low pressure port, 18 ÷ 22 bar [261 ÷ 319 psi]

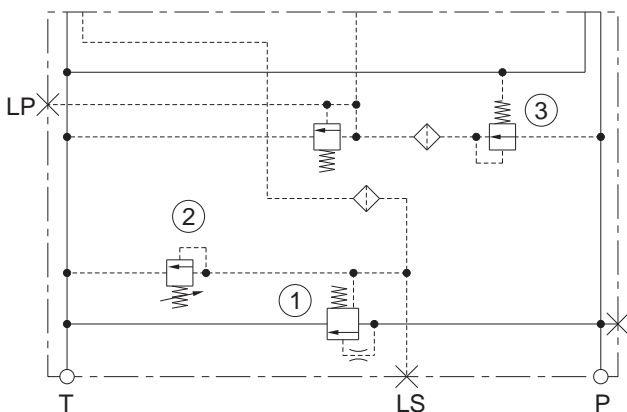

open centre

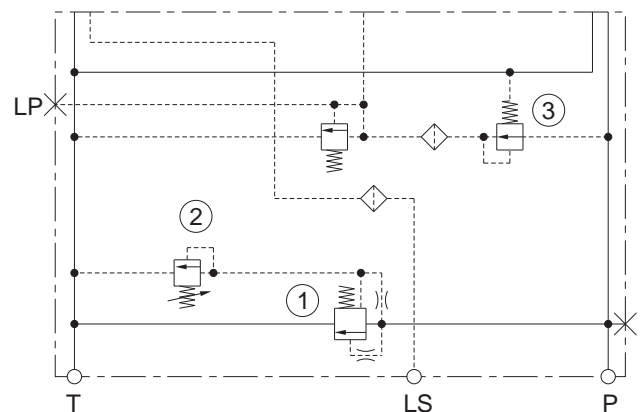

closed centre

Inlet section Open Centre and Closed Centre

HPV 41

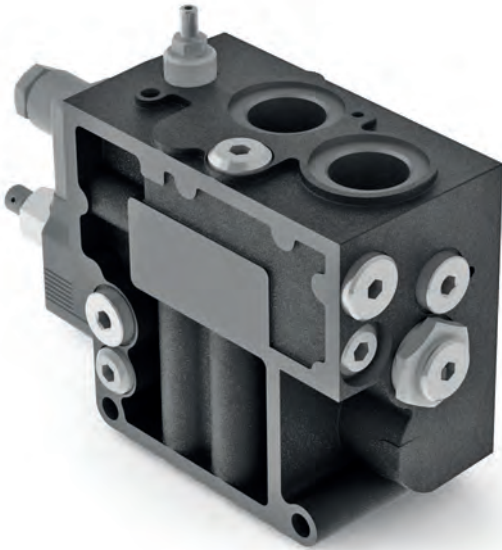

Standard HSE inlet sections with solenoid Ls unloading valve (CRP04HP)

All versions can be supplied with an Ls signal unloading solenoid valve - pos. 4. The solenoid valve can be normally open or normally closed. If it is activated during the work phases it immediately unloads the load sensing signal and subsequently stops all movements of the actuators.

In the open centre versions, the pump unloading pressure value is equal to the sum of the counterpressure acting on the T line plus the pressure required to open the flow/pressure regulator -pos. 1- to connect P to T (often from 8 to 15 bar - 116 to 218 psi).

In the closed centre versions, unloading the Ls signal lowers the pressure in P at a value equal to the stand-by pressure at which the pump is regulated.

Using the solenoid Ls unloading valve on the inlet sections in the open and closed centre versions, we urge grate care in this method, because all functions requiring a lower working pressure, might be operated.

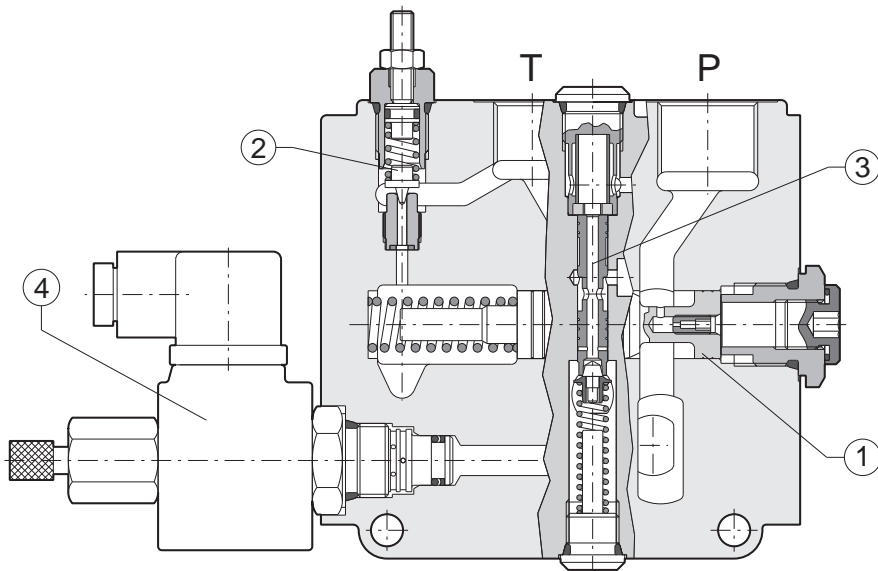

1	3 way flow regulator
2	Pilot pressure relief valve
3	Pressure reduction valve
4	Solenoid Ls unloading valve
Lp	Low pressure port, 18 ÷ 22 bar [261 ÷ 319 psi]

Standard HSE inlet section with solenoid Ls unloading valve (CRP04HP)

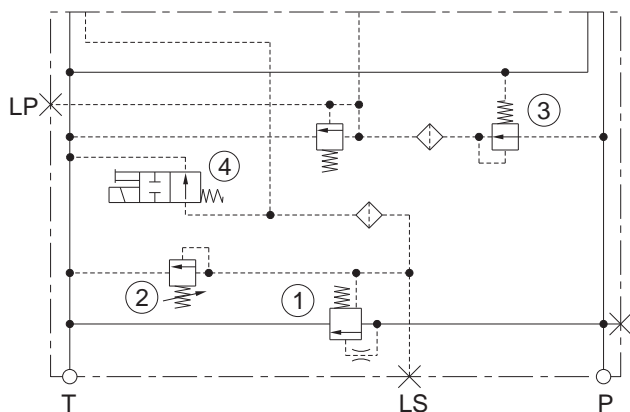

open centre

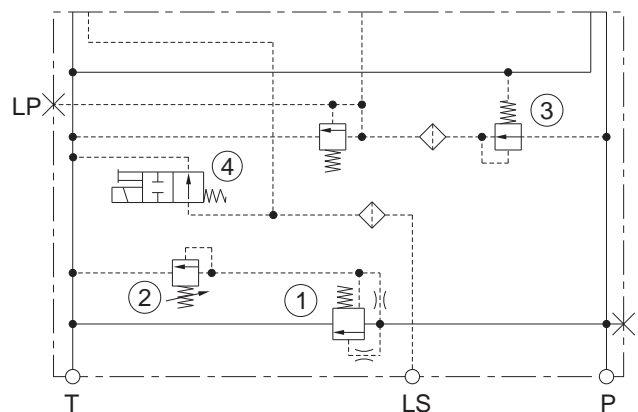

closed centre

Inlet section Open Centre and Closed Centre



Standard HSE inlet sections with pump unloading valve function (HSER)

In the open and closed centre versions, it is possible to mount a **remote-controlled cartridge logic element (pos. 5)** for rapid pump unloading, thus by-passing the flow/pressure regulator (pos. 1).

In this configuration, the pump unloading pressure value is equal to the sum of the counterpressure acting on the T line, plus the pressure required to open the HSER valve (0.6 bar - 8.7 psi) to connect P with T.

With this solution the Δp for pump unloading is much lower than what would be created instead using the Ls signal unloading solenoid valve (see characteristic curves).

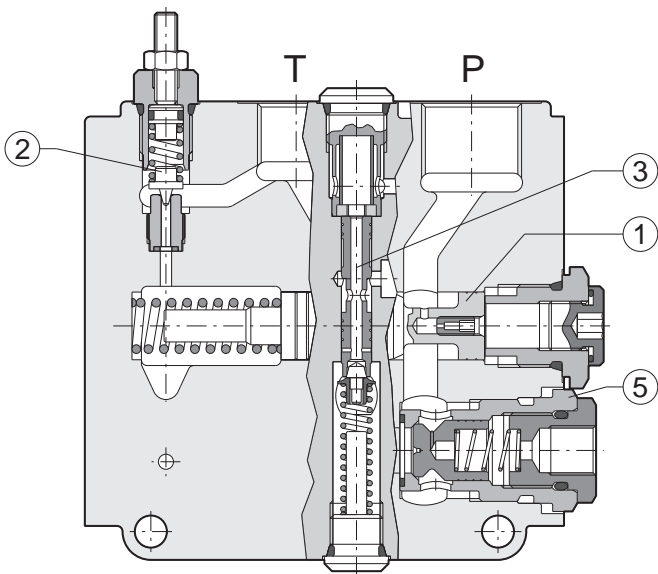

1	3 way flow regulator
2	Pilot pressure relief valve
3	Pressure reduction valve
5	Cartridge logic element, HSER
Lp	Low pressure port, 18 ÷ 22 bar [261 ÷ 319 psi]

Standard HSE inlet section with pump unloading valve function (HSER)

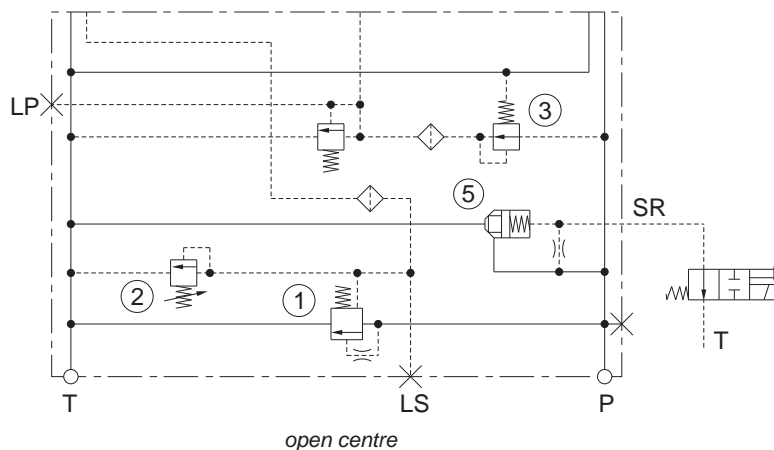

Open center systems

With the spools 15 in the central position, the Ls line, the chamber on the spring side of the flow/pressure regulator (1A) and the chamber on the spring side of the pressure compensator (11) are connected with the exhaust core (T), allowing the pump flow to be conveyed to the tank through the flow/ pressure regulator (1A).

The pump flow, the spring load of the flow/pressure regulator (1A) and the counterpressure acting on the exhaust line (T), determine the pump free circulation pressure (See characteristic curves).

When the spool (15) is activated, the port selected is placed in communication with line P1 and the work pressure through line Ls is sent to the flow/pressure regulator (1A).

The flow obtained will only depend on the crossing area of the spool and the relative Δp that will be created along the spool adjustment range.

If two or more spools operating at different pressure values are activated at the same time, the pressure compensators (11) will keep the pressure drop constant (Δp) and thus the flow on the spools (15) will be constant within the maximum pump flow range.

On the other hand, if two or more spools of elements without pressure compensators are activated simultaneously, the flow on the spools will not be constant but will vary according to the work pressures.

The Load Sensing pressure relief valves (10), using a small pilot line flow, precisely limit the pressure at ports A/B without wasting energy, unlike the anti-shock valve which also when unloading the entire flow of the spools, are very wasteful.

The on-off solenoid valves (13-14) which cut off the LsA and LsB pilot lines, if activated, instantaneously cancel the flow on the relative port.

The pressure reduction valve (6) supplies a low pressure line (18-22 bar [261-319 psi]) which internally feeds the MHPE electrohydraulic modules and, externally, the hydraulic manipulators through the port 22.

The max. work pressures of ports A/B of each element can be remote controlled using the LsA and LsB pilot line ports.

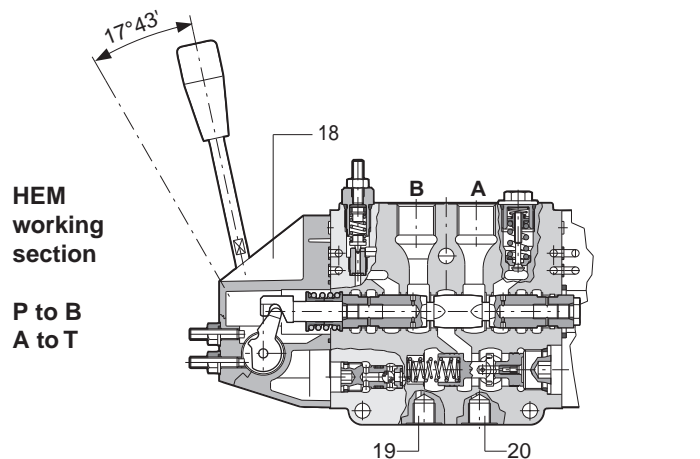
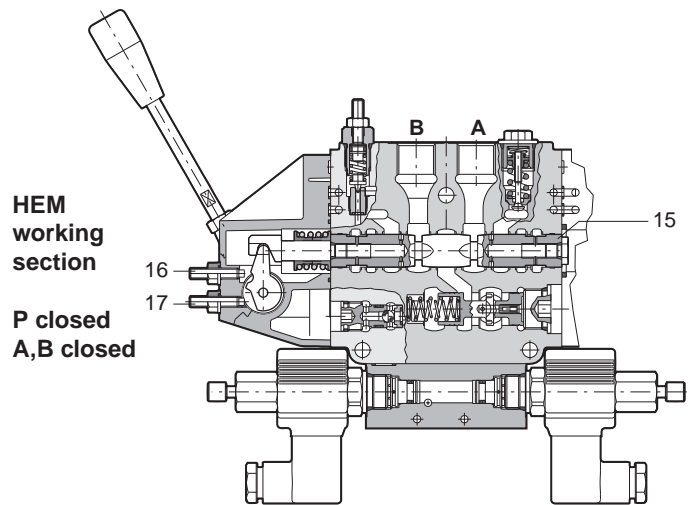
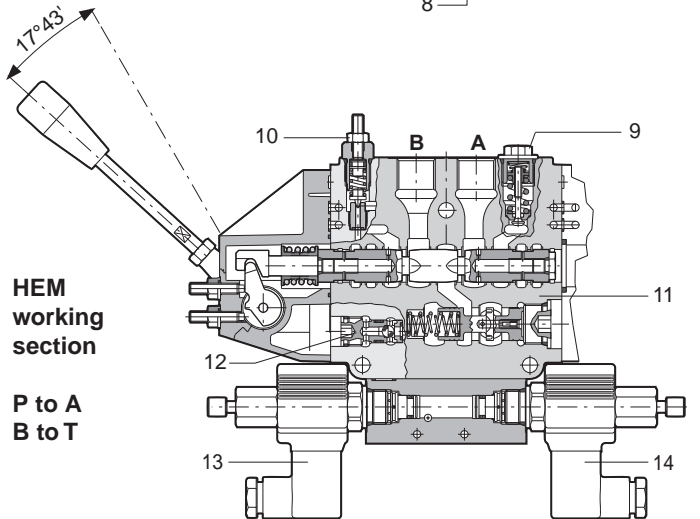
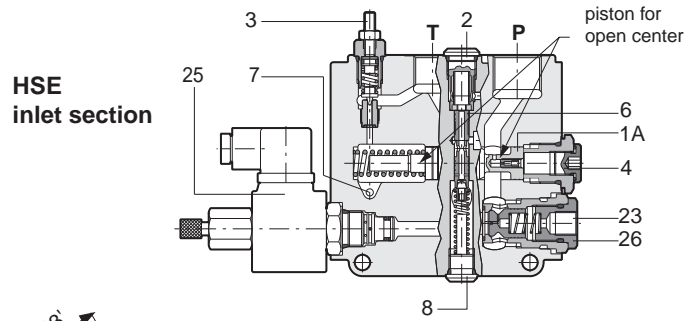

HPV 41

Open center systems

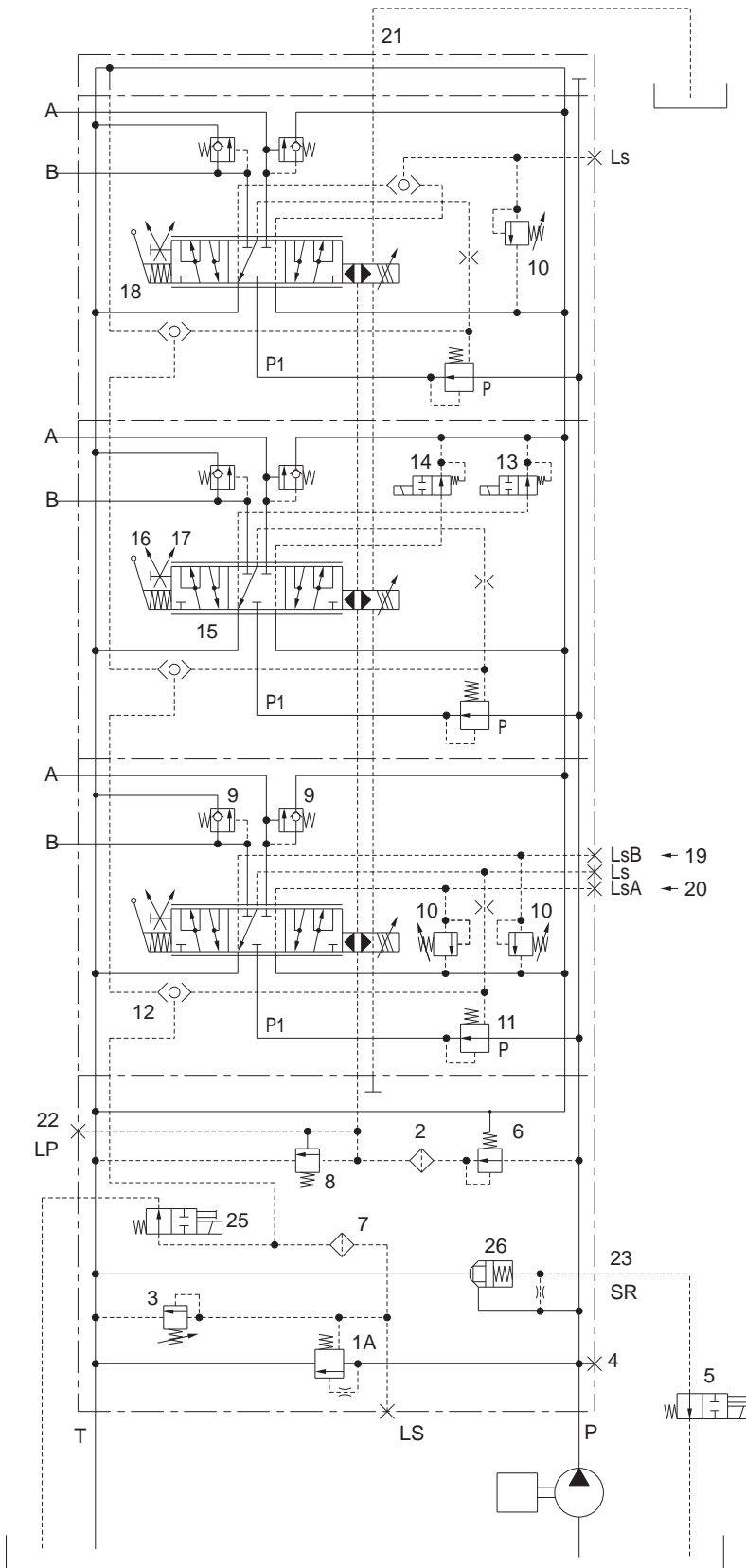

- 1A Flow/pressure regulator
- 2 Low pressure line filter
- 3 Main pressure relief valve
- 4 Pump pressure gauge port
- 5 Pump unloading valve
- 6 Pressure reduction valve
- 7 Load sensing line filter
- 8 Low pressure line relief valve
- 9 Shock and suction valve
- 10 Ls pressure relief valve
- 11 Pressure compensator
- 12 Shuttle valve
- 13 LsB signal unloading solenoid valve
- 14 LsA signal unloading solenoid valve
- 15 Spool
- 16 A port flow fine adjustment register
- 17 B port flow fine adjustment register
- 18 Cover for manual control kinematic motion
- 19 LsB pressure pilot line port
- 20 LsA pressure pilot line port
- 21 Drain port
- 22 Low pressure pilot line port
- 23 Pilot line, pump unloading valve
- 25 Ls signal unloading solenoid valve
- 26 Pump unloading valve

HPV 41

Closed center systems

With the spools (15) in central position, the Ls line, the chamber on the spring side of the pressure compensators (11) and the pump flow/pressure regulator (24) are connected with the return line (T), allowing the pump to shift to the stand-by position.

When the spool (15) is activated, the port selected is placed in communication with line P1 and the work pressure through line Ls is sent to the pump flow/pressure regulator (24).

The flow obtained will only depend on the crossing area uncovered by the spool stroke and on the resulting Δp .

In this way the pump flow will adjust instantaneously to the actual flow required at the ports while keeping the differential pressure constant between the pump and the Ls signal.

The second stage of the pilot line pressure (3) must be set at 20-30 bar [290-435 psi] more than the maximum setting of the pump pressure/flow regulator (24).

If two or more spools operating at different pressure values are activated at the same time, the pressure compensators (11) will keep the pressure drop constant (Δp) and thus the flow at the spools (15) will be constant within the maximum pump flow range.

On the other hand, if two or more spools of elements without pressure compensators are activated simultaneously, the flow on the spools will not be constant but will vary according to the work pressures.

The Load Sensing pressure relief valves (10), activated by a small pilot flow, precisely limit the pressure at ports A/B with no energy dissipation, unlike the anti-shock valves which, also when unloading the entire flow of the spools, are very dissipative.

The on-off solenoid valves (13-14) which cut off the LsA and LsB pilot lines, if activated, instantaneously cancel the flow at the relative port.

From the pressure reduction valve (6) starts a low pressure line (18-22 bar [261-319 psi]) which internally feeds the MHPE electrohydraulic modules and, externally, the hydraulic manipulators through port 22.

The max. work pressures of A/B ports of each element can be remote controlled using the LsA and LsB pilot line ports.

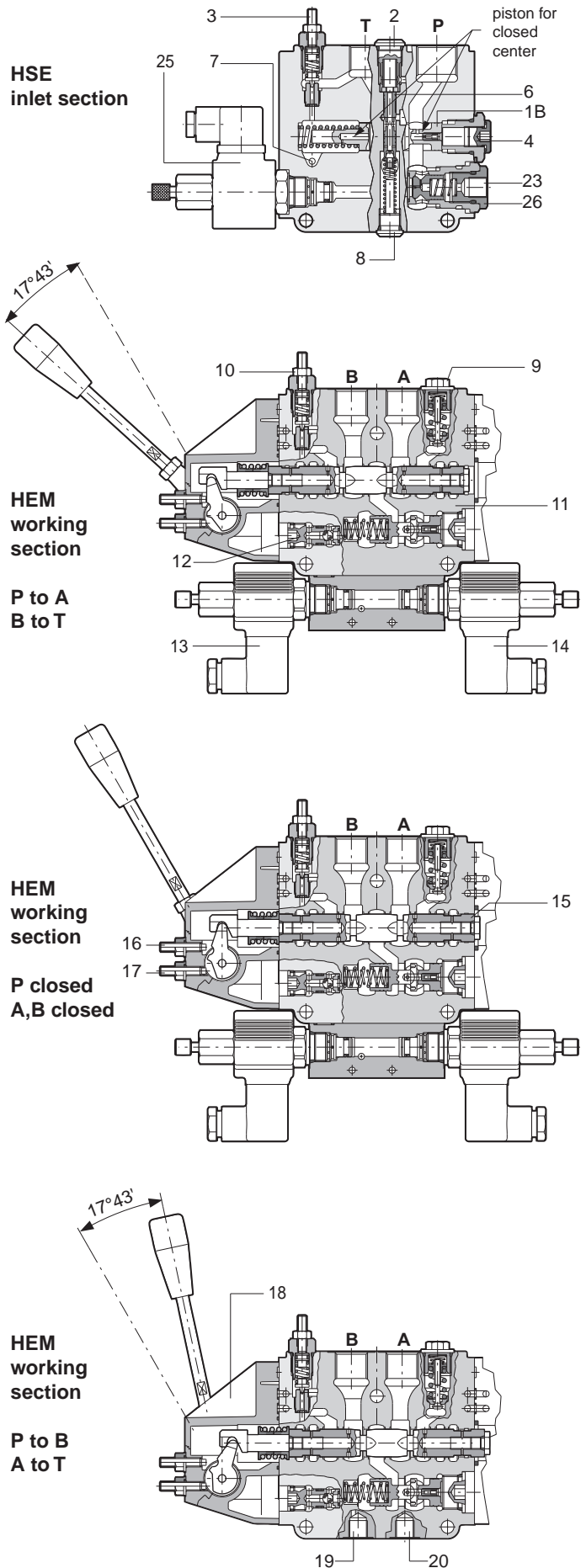

Closed center systems

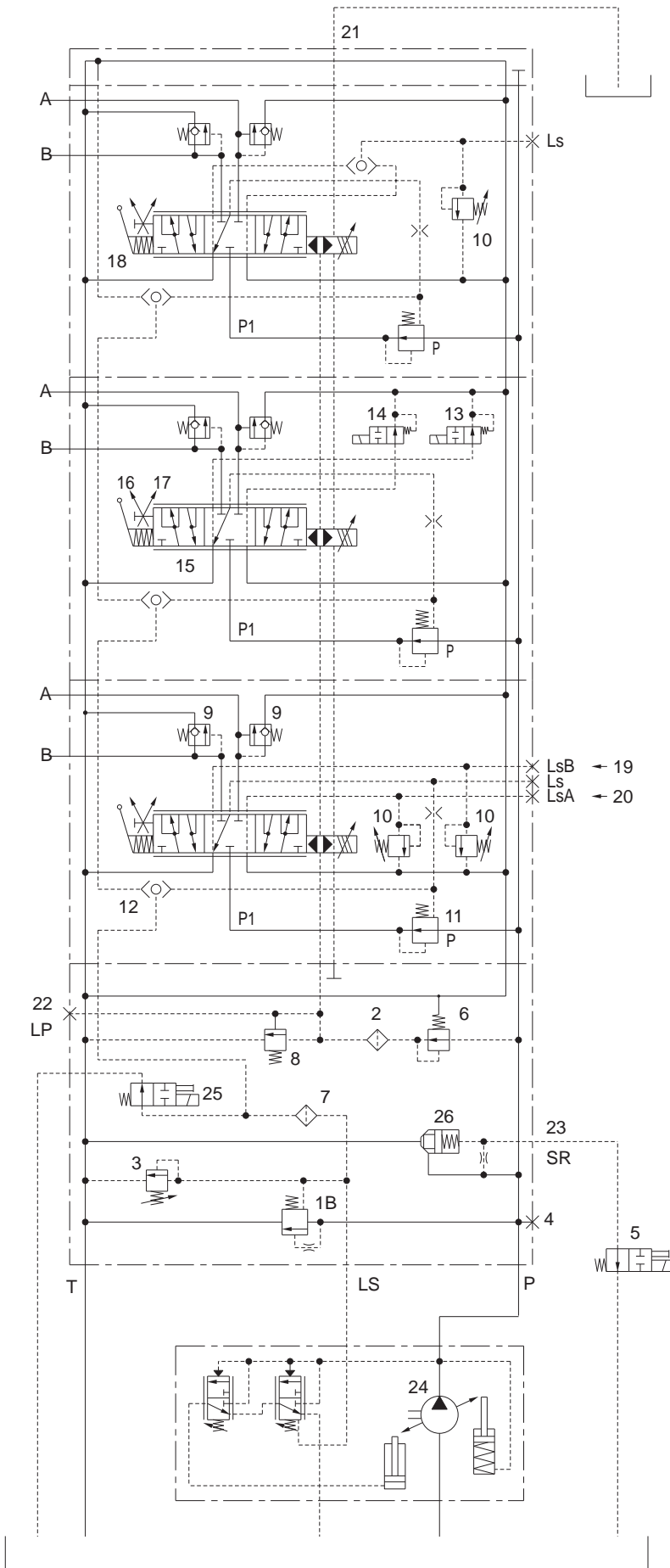

- 1B Pressure regulator first stage
- 2 Low pressure line filter
- 3 Main pressure relief valve
- 4 Pump pressure gauge port
- 5 Pump unloading valve
- 6 Pressure reduction valve
- 7 Load sensing line filter
- 8 Low pressure line relief valve
- 9 Shock and suction valve
- 10 Ls pressure relief valve
- 11 Pressure compensator
- 12 Shuttle valve
- 13 LsB signal unloading solenoid valve
- 14 LsA signal unloading solenoid valve
- 15 Spool
- 16 A port flow fine adjustment register
- 17 B port flow fine adjustment register
- 18 Cover for manual control kinematic motion
- 19 LsB pressure pilot line port
- 20 LsA pressure pilot line port
- 21 Drain port
- 22 Low pressure pilot line port
- 23 Pilot line, pump unloading valve
- 24 Pump flow/pressure regulator
- 25 Ls signal unloading solenoid valve
- 26 Pump unloading valve

HPV 41

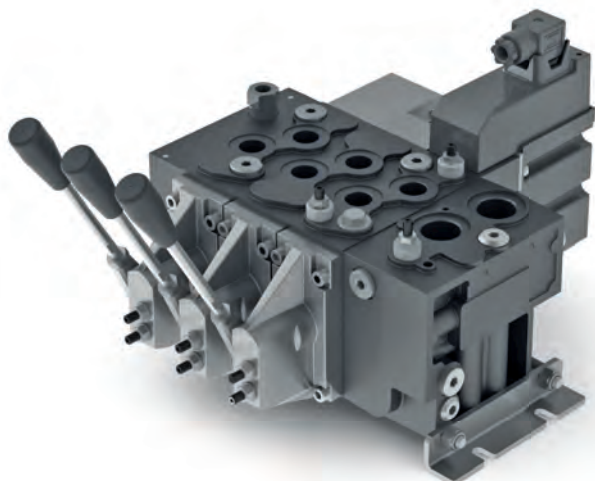

HPV 41

General features

The HPV proportional valves are proportional directional valves with two functional characteristics:

- Directional regulation.
- Flow regulation insensitive to the variation of the load applied to the actuator.

They can be remotely controlled and represent the most advanced technology in the world of applied hydraulics.

Proportional distributors differ in “open center” and “closed center”:

- Proportional open center distributors are used with fixed displacement pumps.
- The closed center proportional valves are used with variable displacement pumps with load sensing control.

Hydraulic features

The hydraulic features reported below were measured using a mineral based hydraulic oil according to DIN 51524 or ISO 6743/4 with a viscosity of 25 mm²/s [130 SUS] at a temperature of 50 °C [122 °F]

Rated flow	HSE inlet section, P port		160 l/min	42 US gpm
	Mid inlet section, HFLS		250 l/min	66 US gpm
	A, B ports with pressure compensator		130 l/min	34 US gpm
	A, B ports without pressure compensator		140 l/min	37 US gpm
Max. working pressure	Connection P / P port	Pressure relief valve setting	400 bar	5800 psi
		Working pressure	370 bar	5370 psi
	Ports A, B		370 bar	5370 psi
	Connection Y		to tank	
	Connection T	Static	25 bar	363 psi
Dynamic		35 bar	508 psi	
Max. pilot pressure oil supply			18 ÷ 22 bar	260 ÷ 320 psi
Oil temperature	Recommended		-30 ÷ 60 °C	-22 ÷ +140 °F
	Min.		-25 °C	-13 °F
	Max.		+80 °C	+176 °F
Ambient temperature			-30 ÷ 60 °C	-22 ÷ +140 °F
Viscosity	Recommended		12 ÷ 80 mm ² /s (cSt)	
	Min.		4 mm ² /s (cSt)	
	Max.		460 mm ² /s (cSt)	
Filtering	Max. contamination: class 9 according to NAS 1638 (20/18/15 according to ISO 4406)			
Stroke	Spool stroke		± 7 mm	± 0.276 in
	Proportional		± 5.5 mm	± 0.217 in
Dead band			± 1.5 mm	± 0.059 in
Nominal internal leakage at 180 bar (2611 psi)	A, B → T	Without anti-shock valves	23 cm ³ /min	1.40 in ³ /min
		With anti-shock valves	29 cm ³ /min	1.77 in ³ /min

HPV 41 internal (easy replacement) filters, mesh 100 µm.

Mineral oil hydraulic fluid: according to DIN 51524 and 51525 or ISO 6743/4. HPV 41 can also be used with phosphorous esters (HFDR), water-glycol /HFC) or water-oil (HFB) mixes, subject to our Technical Dept. approval.

Hydraulic control - MHPH module			
Pilot pressure	Start	4.5 bar	65 psi
	End stroke	15 bar	218 psi
Max. pilot pressure		30 bar	436 psi