

OVERALL DIMENSIONS

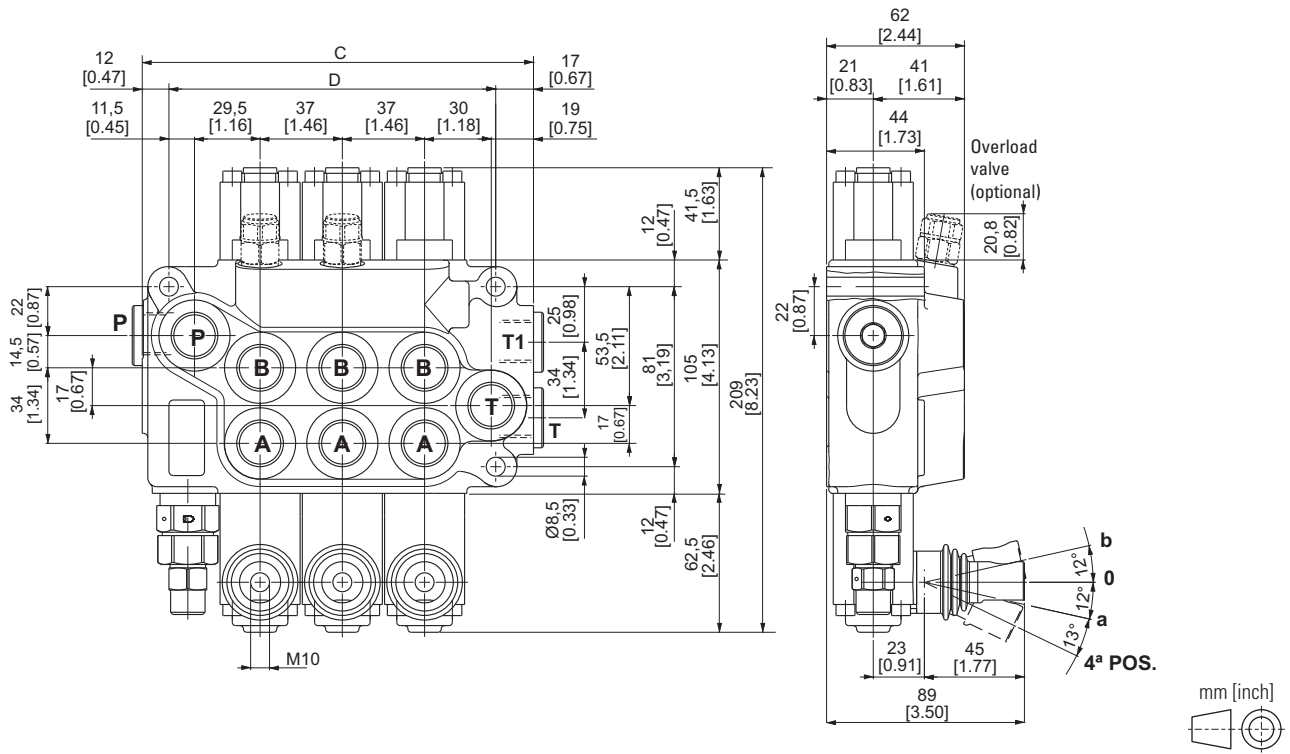

MONOBLOCK

Type	C mm [inch]	D mm [inch]	Weight kg [lb]	Max flow l/min [GPM]	Max pressure BAR [psi]
DCV 40/1	102 [4.02]	73 [2.87]	3.57 [7.85]	70 [18.5]	400 [5800]
DCV 40/2	139 [5.47]	110 [4.33]	5.45 [11.99]		
DCV 40/3	176 [6.93]	147 [5.79]	7.30 [16.06]		
DCV 40/4	213 [8.39]	184 [7.24]	9.15 [20.13]		
DCV 40/5	250 [9.84]	221 [8.70]	11.00 [24.20]		
DCV 40/6	287 [11.30]	258 [10.16]	12.85 [28.27]		

CHARACTERISTIC PRESSURE DROP FLOW CURVES

MONOBLOCK

**Inlet pressure drop between P → T
spool in central position**

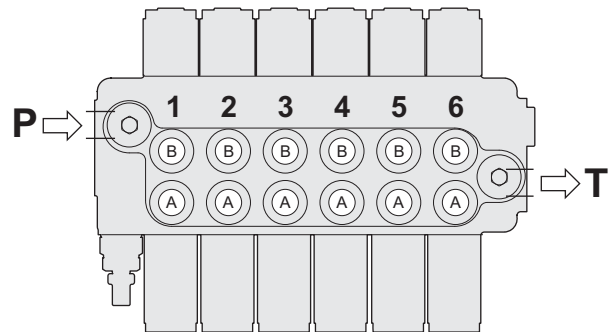
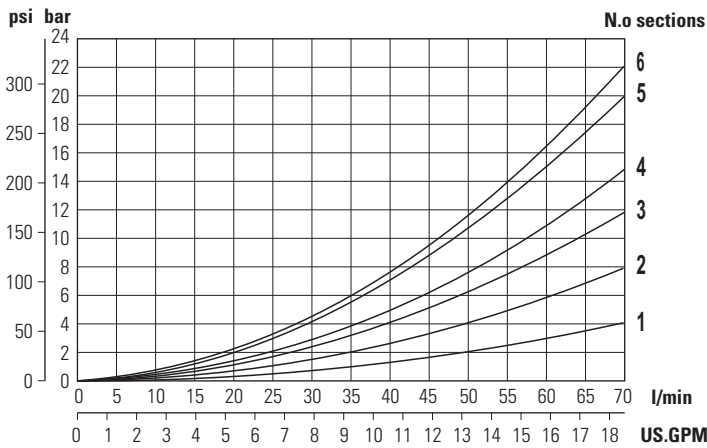

**Inlet pressure drop between P → A (B)
spool in working position**

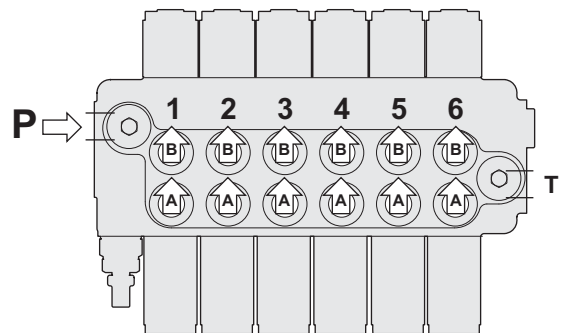
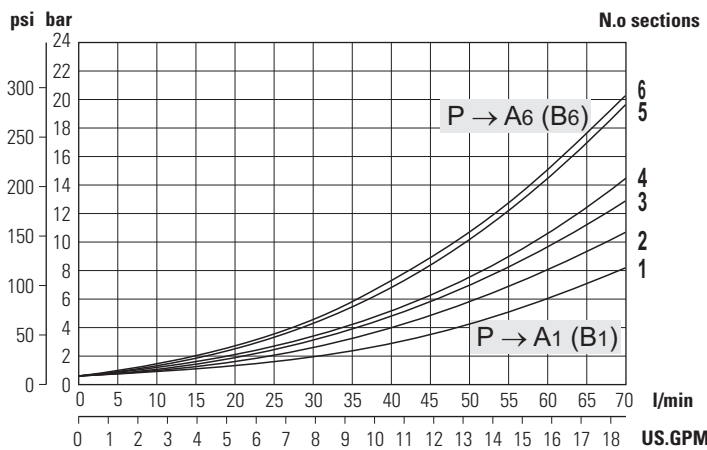

**Inlet pressure drop between A (B) → T
spool in working position**

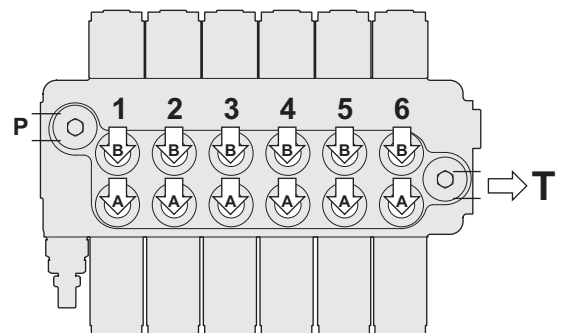
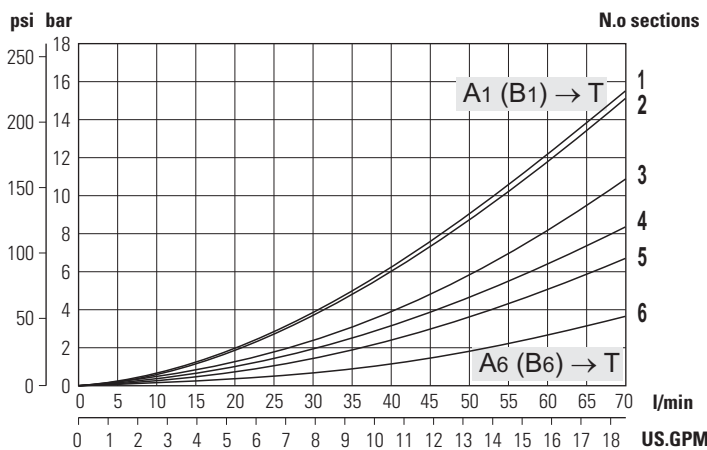

Metering curves are different for each type of spool. Therefore particular curves are supplied on request
The curves are obtained using standard double acting spool (cod. ST1) with oil at 50°C and viscosity 36 mm² / s